

**Course Structure & Syllabus of B.Tech.– Civil Engineering  
Applicable for Batch: 2020-24**

**DIT UNIVERSITY**

**Dehradun**



**Detailed Course Structure & Syllabus**

**of**

**B.Tech. – Civil Engineering**

**(Fully Flexible Choice Based Credit System)**

# Course Structure & Syllabus of B.Tech.– Civil Engineering

## Applicable for Batch: 2020-24

### Introduction

The Ministry of Human Resource Development (MHRD), Govt. of India, has initiated development of a New Education Policy (NEP) to bring out comprehensive reforms in the Indian education system.

The University Grants Commission (UGC) has subsequently initiated several steps to foster academic excellence through introduction of paradigm shift in learning and teaching pedagogy, innovation and improvement in course curricula, examination and education system.

While a majority of education institutions have started following the semester-based system of education, it has been observed that this new system is still producing graduates who lack knowledge, values, skills and are not job ready professional. The reason for this lacking could be attributed to the rigidity of our program structures and lack of flexibility to have choices among core subject education, liberal arts, ability enhancement, skill development, etc., that is fundamental to overall development and employability of these graduates.

To make this possible, a fully flexible choice-based credit system (FFCBCS), a well-established internationally known system, is proposed. This fully flexible choice-based credit system allows students the flexibility to learn at their own pace, and register for both core subjects and a variety of courses from other areas, leading to holistic development of an individual. The FFCBCS will facilitate us to bench mark our programs with best international liberal arts based academic programs.

*Advantages of the FFCBCS structure:*

- Shift in focus from the teacher-centric to student-centric education. Student can curve out their program structure by choosing minimum number of credits from well-defined baskets.
- Student may undertake as many credits as they can cope with.
- FFCBCS allows students to choose courses from various baskets of inter-disciplinary, intra-disciplinary, skill oriented, ability enhancing, and from other disciplines.

### Features unique to DIT University FFCBCS structure

1. A minimum of 150-160 credits has to be earned by a student to be eligible for an Under Graduate degree in Engineering. Each department will decide their total credits for each program, and it can vary across disciplines.
2. Courses are categorized into 11 baskets, and a student will have the option to choose courses in most baskets and earn *minimum number of credits* required in each basket for the award of his/her degree. For each basket, Engineering departments have the flexibility to identify course(s) which will be a core requirement for their program.
3. In certain disciplines, students may choose a *Specialization* by earning 18 credits of Discipline Elective courses towards a particular area of that discipline (intradisciplinary). In addition to this, brighter students will have the option to receive (a) a *Certificate* by earning *additional* 9 credits towards a particular area either inside or outside their discipline, or (b) *Minor* by earning additional 18 credits towards a particular area outside their discipline. Certificates and Minors can be earned through either University courses, or with MOOCs from providers as identified by the University. Each department will design the structures and eligibility conditions for registration to its certificates or minor program, which may be reviewed annually, to keep the *Certificates* and *Minors* contemporary and relevant to latest changes.

# **Course Structure & Syllabus of B.Tech.– Civil Engineering**

## **Applicable for Batch: 2020-24**

4. An Academic Advisory Committee may be formed comprising all HODs/ Programme Coordinator and one representative each from respective departments. Academic Advisory Committee will meet at the end of every semester after the completion of Board of Examination meeting to discuss and finalize course offerings by respective departments in the upcoming semester. Academic Advisory Committee will be chaired by the Dean Academic Affairs/ Deans of respective Schools/ Competent Authority.
5. To provide sufficient flexibility and room during the program for additional *Certificates, Specializations, and Minors*, 8-week summer semesters (Summer 1, Summer 2, and Summer 3) may have to run. Summer semesters are critical for implementing a fully flexible system. Each department will decide *a priori* which courses to offer in the summer semester and get them finalized at the Academic Advisory Committee meeting.
6. Project based learning has to be incorporated as a core component of evaluation in each course, and depending on the level and type of the course, the project can be of several types - Study Oriented Project, Lab Oriented Project, Design Oriented Project, Computer Oriented Project, Projects of Organizational Aspects, Research Projects, or Entrepreneurship and Start Up Projects. A Capstone Project has been introduced in the 8<sup>th</sup> semester for all Bachelor of Technology students.
7. Courses under each basket may be updated on an annual basis.
8. Each student will be advised by a faculty advisor of his/her department for registration of courses from each basket in the beginning of semester, depending upon the availability of seats. A student advising centre may be formed where students will have access to department faculty advisers. Faculty advisers should have complete access to view individual student's academic transcript for advising purposes.
9. A student getting an F grade in a core course (departmental or otherwise) at the end of the semester will have to earn those credits by registering for the same course whenever it is offered in subsequent semesters. If the course is not a core course, the student may choose to register for any other course next semester in that basket as advised by the department faculty adviser. Additional fees for those number of credits may apply.
10. Students may opt for summer training/internships/industrial tours as advised by the department. However, these activities will not have credits.

# Course Structure & Syllabus of B.Tech.– Civil Engineering

## Applicable for Batch: 2020-24

### Baskets of FFCBCS

11 baskets of courses have been identified to provide student comprehensive exposure to a large number of areas, leading to the holistic development of an individual. These baskets are as follows:

- 1. Language and Literature:** These include courses related to English or other popular languages worldwide, communication skills, and literature. These courses are of 3 credits each.
- 2. Core Science:** These courses include science courses from the disciplines of Physics and Chemistry. These courses are of 5 credits each.
- 3. Core Mathematics:** This basket includes courses from Mathematics department, crafted for Engineering students. These courses are of 4 credits each.
- 4. Engineering Sciences:** This basket includes introductory courses from various disciplines of Engineering designed to provide the student solid foundation to the domain of engineering. These courses are of 4 credits each.
- 5. Discipline Core:** This basket includes compulsory courses in the discipline in which the student is admitted to the University. These courses are of 4 credits each.
- 6. Discipline Elective:** This basket provides students courses other than discipline core, and are normally in certain specialized areas. These courses are of 3 credits each.
- 7. Humanities and Liberal Arts:** This basket includes liberal arts courses in various disciplines like psychology, management, economics, etc., and are of 3 credits each.
- 8. Skill Enhancement:** Courses in this basket are primarily hands-on and aims to allow students acquire skills required in certain disciplines that are currently in high demand in the job market. These courses are of 2 credits each.
- 9. Ability Enhancement:** These courses aim to enhance knowledge and ability of an individual in certain required areas related to national and societal interest. Courses in this basket are of 2 credits each.
- 10. Free Electives:** Student can register for any three courses outside their department of his/her choice. These courses can also be taken from MOOCs, and a minimum of 9 credits have to be taken by a student in this basket. These courses are of 3 credits each.
- 11. Capstone Project:** Capstone project is a semester long multifaceted experimental/research assignment that serves as a culminating academic and intellectual experience for students, taken in the last semester of study. It is of 12 credits and may be done groups of not more than three students, and in three modes as follows:
  - **Mode A:** Project with a department faculty.
  - **Mode B:** Project as part of Industry Internship arranged only by the career and placement service of the University. Students securing this assignment on their own will not be allowed, unless the project is secured at a well-known industry, and duly approved by the department. The department's decision in all such cases will be final.
  - **Mode C:** Semester long project in an academic institute/lab of National/International Importance, secured by students on their own. The department's decision to allow in all such cases will be final.

A separate rule booklet will be released for implementation of Capstone Project.

# Course Structure & Syllabus of B.Tech.– Civil Engineering

## Applicable for Batch: 2020-24

### Structure of the Undergraduate program in Civil Engineering

Basket/Area	Min Credits To be taken	Credit per course	Courses
<b>Language and Literature (LL)</b> Core: Professional Communication Elective: Choose any 1 more LL course	6	3	2
<b>Core Sciences (CoS)</b> Core: None Elective: Choose any 2 CoS course	10	5	2
<b>Core Mathematics (CM)</b> Core: Maths I, Maths II, and Mathematics III Elective: None	12	4	3
<b>Engineering Sciences (ES)</b> Core: Data Structure, Programming for Problem Solving Elective: Choose any 2 more ES courses	16	4	4
<b>Discipline Core (DC)</b> Core: As per plan of study	52	4	13
<b>Discipline Elective (DE)</b> Elective: Choose any 6 courses as per the Specialization	18	3	6
<b>Humanities and Social Sciences (HSS)</b> Core: None Elective: Choose any 3 more HSS Courses	9	3	3
<b>Skill Enhancement Courses (SEC)</b> Core: None Elective: Choose any 4 SEC Courses	8	2	4
<b>Ability Enhancement Courses (AEC)</b> Core: Aptitude and Soft Skills, Entrepreneurship and Startups, Env. Sc., Indian Constitution	8	2	4
<b>Free Electives (FE)</b> Elective: Choose any 3 courses across University course offerings	9	3	3
<b>Thesis Project (TP)</b> Mode A: Project with a department faculty Mode B: Project as part of Industry Internship Mode C: Project in an academic institute/lab of National Importance. All Modes must be semester long	12	12	1
<b>Total Credits</b>	160	45	47

\* Credits in SEC and AEC courses may vary.

# Course Structure & Syllabus of B.Tech.– Civil Engineering

## Applicable for Batch: 2020-24

Course Baskets: University FFCBCS Baskets (other than DC/DE) for B.Tech Programs. A \* against a course means it is a core course for all B. Tech students.

Course Code	FFCBCS Baskets (other than DC/DE)				
	<b>Language and Literature (min 6 credits to be taken)</b>	<b>Credits</b>			
	<b>Name of Courses</b>	L	T	P	C
LAF181	Professional Communication*	2	0	2	3
LAF182	Indian English Literature	3	0	0	3
LAF183	English Language Teaching	3	0	0	3
	<b>Core Science (min 10 credits to be taken)</b>				
	<b>Name of Courses</b>	L	T	P	C
CHF101	Engineering Chemistry (For CS/IT/EE/ECE)	3	1	2	5
CHF102	Applied Engineering Chemistry (for ME/CE/PE)	3	1	2	5
PYF101	Wave & Optics and Introduction to Quantum Mechanics	3	1	2	5
PYF102	Introduction to Mechanics	3	1	2	5
PYF103	Electricity & Magnetism	3	1	2	5
	<b>Core Mathematics (min 12 credits to be taken)</b>				
	<b>Name of Courses</b>	L	T	P	C
MAF101	Engineering Mathematics I *	3	1	0	4
MAF102	Engineering Mathematics II*	3	1	0	4
MAF201	Engineering Mathematics III (EE, ME, CE)	3	1	0	4
MAF202	Probability and Statistics(CSE, IT, ECE, PE)	3	1	0	4
	<b>Engineering Sciences (min 20 credits to be taken)</b>				
	<b>Name of Courses</b>	L	T	P	C
ECF101	Fundamental of Electronics Engineering	3	0	2	4
EEF101	Basic Electrical Engineering	3	0	2	4
EEF143	Electrical and Electronics Engineering Practice (non EE/EECE)	3	0	2	4
MEF101	Thermodynamics	3	1	0	4
CSF101	Programming for Problem Solving*	3	0	2	4
CSF102	Data Structures*	3	0	2	4
MEF102	Engineering Graphics	2	0	4	4
MEF103	Engineering Mechanics*	2	1	2	4
MEF201	Mechanical Engineering Materials	3	0	2	4
PEF204	Fluid Mechanics	3	0	2	4
EEF141	Electrical Engineering Materials	3	0	2	4
ECF142	Fundamental of Semiconductor Electronics	3	1	0	4
CEF101	Civil Engineering Materials	3	1	0	4
	<b>Name of Courses</b>	L	T	P	C
CEFXXX	Technical Training I	0	0	4	2
CEFXXX	Technical Training II	0	0	4	2
CEFXXX	Value Added Training I	0	0	4	2

## Course Structure & Syllabus of B.Tech.– Civil Engineering

### Applicable for Batch: 2020-24

CEFXXX	Value Added Training II	0	0	4	2
SWAYXXX	MOOCS Courses (as advised by the departments)	2	0	0	0
	<b>Ability Enhancement (min 8 credits to be taken)</b>				
	<b>Name of Courses</b>	L	T	P	C
CHF201	Environmental Science*	2	0	0	2
LAF285	Indian Constitution*	2	0	0	2
MEF483	Entrepreneurship and Start-ups*	0	0	4	2
UCF201	Aptitude and Soft Skills*	2	0	0	2
	<b>Humanities and Liberal Arts (min 9 credits to be taken)</b>				
	<b>Name of Courses</b>	L	T	P	C
LAF281	Introduction to Psychology	3	0	0	3
LAF381	Positive Psychology & Living	3	0	0	3
LAF481	Application of Psychology	3	0	0	3
LAF282	Human Values	3	0	0	3
LAF283	Literature, Language & Society	3	0	0	3
LAF284	Principles of Management	3	0	0	3
LAF482	Intellectual Property Rights	3	0	0	3
LAF382	Engineering Economics	3	0	0	3
	<b>Free Electives (min 9 credits to be taken)</b>				
	<b>Name of Courses</b>	L	T	P	C
ECF481	Analogue Electronics	2	0	2	3
ECF482	Cellular Communication Network	2	0	2	3
ECF381	Microcontroller	2	0	2	3
ECF382	Bio Medical Instrumentation	2	0	2	3
ECF483	Digital Image processing	2	0	2	3
CSF381	Software Project Management	3	0	0	3
CSF345	Introduction to Data Science	3	0	0	3
CSF482	Introduction to Cyber security	3	0	0	3
MEF381	Composites materials	3	0	0	3
MEF481	Total Quality Management	3	0	0	3
MEF482	Renewable Energy Sources	3	0	0	3
PEF381	Carbon Capture and Sequestration	3	0	0	3
PEF491	Polymer Technology	3	0	0	3
PEF492	Health, Safety and Environment in Industry	3	0	0	3
CEF281	Properties of Materials	3	0	0	3
CEF382	Disaster Preparedness Planning & Management	3	0	0	3
CEF481	Environmental Management & Sustainability	3	0	0	3
CEF482	Natural Dynamics	3	0	0	3
CEF483	GIS	3	0	0	3
CEF484	Resource Dynamics and Economic Implications	3	0	0	3

# Course Structure & Syllabus of B.Tech.– Civil Engineering

## Applicable for Batch: 2020-24

Project (12 credits)						
UCF439	Capstone Project	0	0	12	12	
<b>Discipline Core (52 credits)</b>						
Name of Courses	Pre – requisite Courses	L	T	P	C	
CEF201	Fluid Mechanics	None	2	1	2	4
CEF202	Strength of Materials	PYF 102	3	0	2	4
CEF203	Geomatics Engineering	None	2	1	2	4
CEF204	Water supply Engineering	None	2	1	2	4
CEF205	Sewage and Solid Waste Engineering	CEF204	2	1	2	4
CEF206	Structural Analysis I	CEF202	2	1	2	4
CEF207	Concrete Technology	None	3	0	2	4
CEF208	Transportation Engineering I	None	2	1	2	4
CEF301	Soil Mechanics	CEF202	2	1	2	4
CEF302	Design of Reinforced Concrete Structures	CEF202, CEF206	3	1	0	4
CEF303	Design of Steel Structures	CEF202, CEF206	3	1	0	4
CEF304	Structural Analysis II	CEF206	3	1	0	4
CEF401	Estimation and Costing	CEF302	3	1	0	4
<b>Departmental Electives (18 Credits)</b>						
Name of Courses		L	T	P	C	
CEF341	Engineering Geology	2	0	2	3	
CEF342	Hydraulics and Hydraulic Machines	2	1	0	3	
CEF343	Environmental Risk Assessment and Disaster Management	3	0	0	3	
CEF344	Hydraulic Structures and Hydro Power Engineering	2	1	0	3	
CEF345	Green Buildings and Energy Conservation	3	0	0	3	
CEF346	Water and Land Management	3	0	0	3	
CEF347	Port & Harbour Engineering	2	1	0	3	
CEF348	Air & Water Pollution	3	0	0	3	
CEF349	Remote sensing and Image processing	3	0	0	3	
CEF351	Prestressed Concrete	2	1	0	3	
CEF352	Earthquake Engineering	3	0	0	3	
CEF353	Traffic Engineering and Management	2	1	0	3	
CEF354	Transportation Engineering II	3	0	0	3	
CEF355	Building Science	2	0	2	3	
CEF356	Foundation Engineering	3	0	0	3	
CEF357	Hydrology and Irrigation Engineering	3	0	0	3	
CEF441	Advanced Highway Engineering	2	1	0	3	
CEF442	Bridge Engineering	2	1	0	3	
CEF443	Environmental Management and Sustainable Development	3	0	0	3	
CEF444	Finite Element Analysis	2	1	0	3	
CEF445	Soil Dynamics and Machine Foundation	2	1	0	3	
CEF446	Advanced Reinforced Concrete Structures Design	2	1	0	3	



# Course Structure & Syllabus of B.Tech.– Civil Engineering

## Applicable for Batch: 2020-24

CEF447	Construction Planning and Project Management	2	1	0	3
--------	--	---	---	---	---

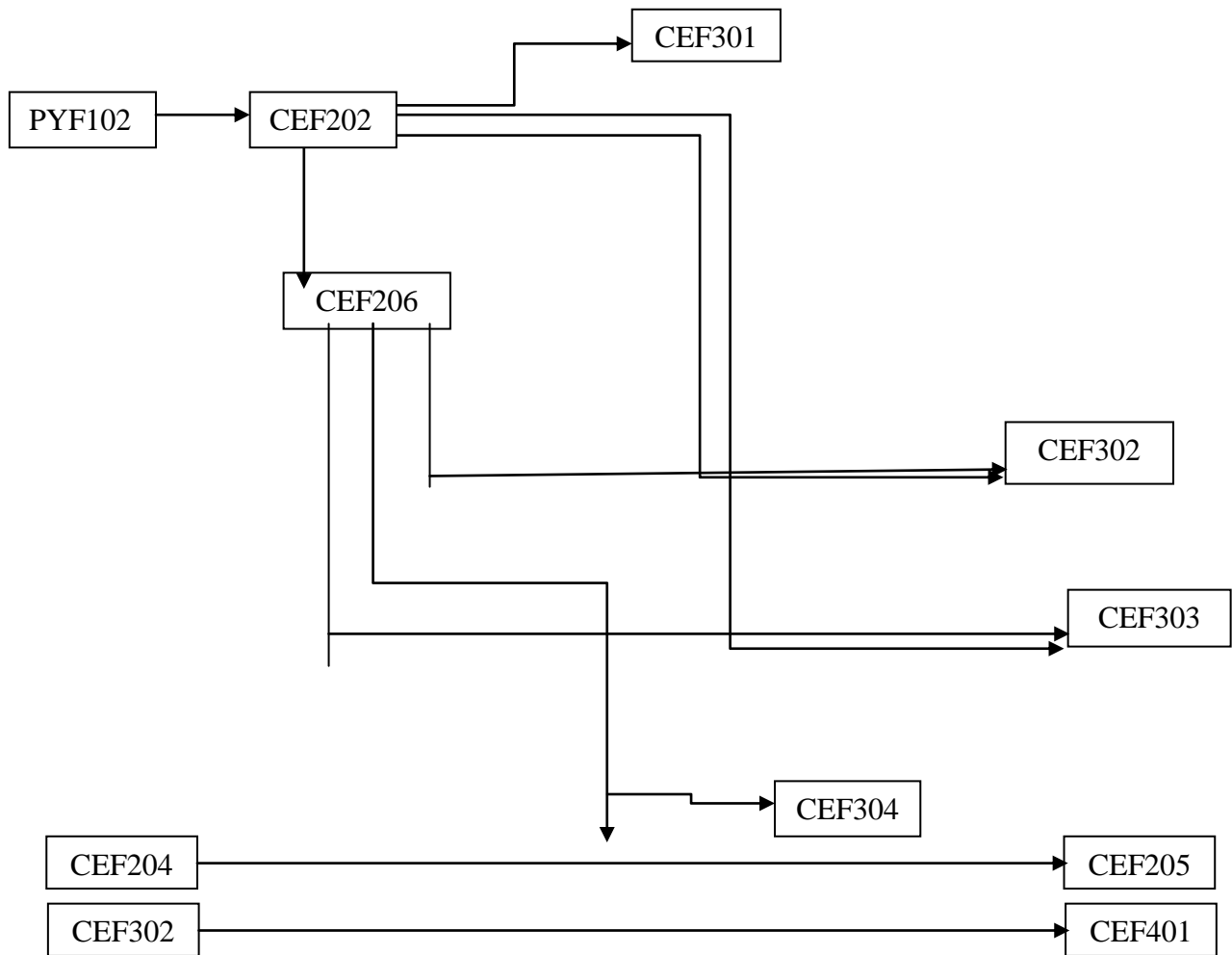

**Figure: Flowchart of pre-requisites for the DC courses**

# **Course Structure & Syllabus of B.Tech.– Civil Engineering**

## **Applicable for Batch: 2020-24**

**After release of Final Exam results, Academic Advisory Committee meets to decide & finalize course offerings in each basket**



**Courses are created in SAP and in LMS with required number of seats**



**Registrar announces the date for Registration**



**Students get advised and registers for courses in the Student Advising Centre**



**List of students gets added in LMS**



**Class Starts**

**Flow of Actions for implementing FFCBCS every semester**

# **Course Structure & Syllabus of B.Tech.– Civil Engineering**

## **Applicable for Batch: 2020-24**

### **UNDERGRADUATE COURSE DESCRIPTION DOCUMENT**

<b>1. Department offering the course</b>	<b>Humanities &amp; Liberal Arts</b>
<b>2. Course Code</b>	<b>LAF181</b>
<b>3. Course Title</b>	<b>Professional Communication</b>
<b>4. Credits (L:T:P:C)</b>	<b>2:0:2:3</b>
<b>5. Contact Hours (L:T:P)</b>	<b>2:0:2</b>
<b>6. Prerequisites (if any)</b>	<b>NIL</b>
<b>7. Course Basket</b>	<b>Language and Literature</b>

#### **8. Course Summary**

This course is to enhance the Communication Skills of the students. It also focuses on Basic facets of communication. It introduces the students to LSRW and Non-verbal Language and how to master these aspects to be an effective communicator.

#### **9. Course Objectives**

The course aims at developing the LSRW skills of students for effective communication. Also to equip them for a business environment. It also focusses at preparing the students understand and present themselves effectively.

#### **10. Course Outcomes**

**On successful completion of the course, students will be able to achieve the following:**

1. Communicate smoothly
2. Greater self-confidence and knowledge of life skills helps them to develop healthier interpersonal relationships.
3. Present themselves effectively
4. Prepares the students to face future challenges and excel in their personal and professional lives.

#### **11. Curriculum Content**

##### **Unit 1: Communication**

Communication: Meaning, Types of Communication: General & Technical Communication  
Knowledge and adoption of Non Verbal cues of communication: Kinesics, Proxemics, Chronemics, Oculistics, Haptics, Paralinguistics, Barriers to Communication, Overcoming strategies.

##### **Unit 2: Listening & Speaking Skills**

Listening Comprehension: identifying General & Specific information, Note taking and drawing inferences

Introduction to Phonetics: Articulation of consonants and vowel sounds.

##### **Unit 3: Reading Skills & Technical Writing Skills**

Reading Strategies and Vocabulary Building Reading Comprehension, Paragraph development, Intra office Correspondence: Notice, Agenda, Minutes and Memorandum Technical Proposal & Report

# **Course Structure & Syllabus of B.Tech.– Civil Engineering**

## **Applicable for Batch: 2020-24**

### **Unit 4: Communication at Work**

Business Letter Writing, Job Application Letter & Resume, Interview Skills, Impression Management, SWOT Analysis (Identifying Strength & Weakness), EQ and Its Dimensions

### **Textbook(s)**

1. Rizvi, Ashraf. Effective Technical Communication, McGraw Hill, New Delhi. 2005.
2. Raman, Meenakshi and Sangeeta Sharma,. Technical Communication: Principles and Practice, 2nd Edition. New Delhi: Oxford University Press. 2011.

### **Reference Books**

1. Aslam, Mohammad. Introduction to English Phonetics and Phonology Cambridge.2003.
2. Ford A, Ruther. Basic Communication Skills; Pearson Education, New Delhi.2013.
3. Gupta, Ruby. Basic Technical Communication, Cambridge University Press, New Delhi.2012.
4. Kameswari, Y. Successful Career Soft Skills and Business English, BS Publications, Hyderabad.2010.
5. Tyagi, Kavita& Padma Misra. Basic Technical Communication, PHI, New Delhi. 2011.
6. Ghosh, B. N. Managing Soft skills for Personality development,Laxmi Publications Ltd., New Delhi, 2013.
7. Elizabeth B. Hurlock. Personality Development , TMH Publication,2010

### **12. Teaching and Learning Strategy**

All materials (ppts, assignments, labs, etc.) will be uploaded in Moodle. Assignments, Class Tests etc. will be done. Various teaching methods like Discussion Method, Case Study Method and Lecture Method will be adopted.

# Course Structure & Syllabus of B.Tech.– Civil Engineering

## Applicable for Batch: 2020-24

1. Department offering the course	Humanities & Liberal Arts
2. Course Code	LAF182
3. Course Title	Indian English Literature
4. Credits (L:T:P:C)	3:0:0:3
5. Contact Hours (L:T:P)	3:0:0
6. Prerequisites (if any)	NIL
7. Course Basket	Language and Literature

### 8. Course Summary

- Indian English Literature is an honest enterprise to demonstrate the ever rare gems of Indian Writing in English. From being a singular and exceptional, rather gradual native flare – up of geniuses, Indian Writing has turned out to be a new form of Indian culture and voice in which India converses regularly. This course will introduce various authors and will help to understand the role of literature in reflecting the social context and the shaping of a young nation.

### 9. Course Objectives

- The course will enable the students to understand the level of Indian English Literature.
- It will also enable the students to understand different genres such as prose, poetry, and fiction in Indian Writers in English.

### 10. Course Outcomes

**On successful completion of the course, students will be able to achieve the following:**

**Course Outcome:**

- The students will develop an insight into Indian literature.
- The students will learn to appreciate different genres of literature of Indian Literature in English.
- The students will understand the role of literature in reflecting the social context and the shaping of a young nation.
- The students will demonstrate knowledge and comprehension of major texts and traditions of language and literature written in English as well as their social, cultural, theoretical, and historical contexts.

### 11. Curriculum Content

#### Unit 1

##### Prose

APJ Abdul Kalam: Unity of Minds

Swami Vivekananda: The Cosmos-Macrocosm

Mahatma Gandhi: Hind Swaraj, What is Civilization? (Chapter XIII) Education (Chapter XVIII)

#### Unit II

##### Poetry

Toru Dutt:

Our Casuarina Tree

# **Course Structure & Syllabus of B.Tech.– Civil Engineering**

## **Applicable for Batch: 2020-24**

Rabindranath Tagore:	Geetanjali – Where the mind is without fear
Sri Arbindo:	Stone Goddess
Sarojani Naidu:	Life
Nissim Ezekiel:	The Night of Scorpion
Kamla Das:	An Introduction

### **Unit III**

#### **Short Stories**

R.N.Tagore:	Kabuliwala
Mulk Raj Anand:	Duty
R.K. Narayan:	An Astrologer's Day
NayantaraSehgal:	Martand

### **Unit IV**

#### **Novel**

Ruskin Bond: Flights of Pigeons

#### **Textbook(s).**

1. Kumar, Shiv K. (ed), Contemporary Indian Short Stories in English, 2007 SahityaAkademi.
2. Anand, Mulk Raj; SarosCowasjee (ed.); Selected Short Stories Penguin Books, 2006
3. Bond, Ruskin. Flights of Pigeons, Penguin Books, 2003

#### **Reference Books**

1. Tagore, Rabindra. *Nationalism*. Delhi: Rupa Publications, 1992.Print.
2. Chinhade, Sirish. *Five Indian English Poets*. New Delhi: Atlantic Publishers and Distributors, 1996.Print.
3. Naik, M.K. *A History of Indian English Literature*. New Delhi: SahityaAkademi, 2004.Print.
4. Agrawal, K.A. Ed. *Indian Writing In English: A Critical Study*. Atlantic Publishers &Dist, 2003.Print.

#### **12. Teaching and Learning Strategy**

All materials (ppts, assignments, labs, etc.) will be uploaded in Moodle. Refer to your course in Moodle for details.

# Course Structure & Syllabus of B.Tech.– Civil Engineering

## Applicable for Batch: 2020-24

1. Department offering the course	Humanities & Liberal Arts
2. Course Code	LAF183
3. Course Title	English Language Teaching (ELT)
4. Credits (L:T:P:C)	3:0:0:3
5. Contact Hours (L:T:P)	3:0:0
6. Prerequisites (if any)	NIL
7. Course Basket	Language and Literature

### 8. Course Summary

This course will offer a historical perspective to the teaching of English as a second language. It will trace the changes in language teaching methods throughout history depending on changes in the kind of proficiency learners need. It includes the different approaches used over the years and their application in teaching English as a second language in the classroom. It also traces the status of English language and the 'World English' and how it affects the teaching of English.

### 9. Course Objectives

To introduce students to the nature of English language learning and its theoretical implications. The main objective of the course is to enable students to evaluate a variety of language learning methods and approaches. It also aims to empower students to understand ELT in their contexts of language learning.

### 10. Course Outcomes

**On successful completion of the course, students will be able to achieve the following:**

1. Students will learn about communicative approaches to English language teaching.
2. Be able to understand the theories and methodologies of ELT
3. Be able to explore core components of communicative language teaching
4. Students will learn to apply ELT theories

### 11. Curriculum Content

#### Unit 1

Historical Perspective , ELT and its beginnings: development of reading approach, oral method and audio-lingual method

#### Unit 2

Communicative Language Teaching (CLT): the concept of 'communicative competence; ESL in India: a historical trajectory

#### Unit 3

Halliday's notion of 'transitivity' and 'meta-functions'

Corpus Linguistics ELT: corpus studies and how it can be used for language teaching

#### Unit 4

'World English' and ELT, Model of the 'Concentric Circles' and its impact on ELT

# **Course Structure & Syllabus of B.Tech.– Civil Engineering**

## **Applicable for Batch: 2020-24**

### **Textbook(s)**

1. Maybin, Janet and Swann, Joan. (2009). The Routledge Companion to English Language Studies. London: Routledge, Print

### **Reference Books**

1. Richards, J. & T.S. Rogers. (1986). Approaches and Methods in Language Teaching. Cambridge: Cambridge University Press, Print.
2. Ur, Penny. (1996). A Course in Language Teaching: Practice and Theory. Cambridge: Cambridge University Press, Print.

### **12. Teaching and Learning Strategy**

All materials (ppts, assignments, labs, etc.) will be uploaded in Moodle. Refer to your course in Moodle for details.



# Course Structure & Syllabus of B.Tech.– Civil Engineering

## Applicable for Batch: 2020-24

1. Department offering the course	Physics
2. Course Code	PYF101
3. Course Title	Wave & Optics and Introduction to Quantum Mechanics
4. Credits (L:T:P:C)	3:1:2:5
5. Contact Hours (L:T:P)	3:1:2
6. Prerequisites (if any)	NIL
7. Course Basket	Core Sciences

### 8. Course Summary

### 9. Course Objectives

The objective of this course is to develop a fundamental basis of waves, optical phenomenon, concepts of quantum mechanics and semiconductor physics which the engineering students can apply to their respective area of specialization.

### 10. Course Outcomes

On successful completion of the course, students will be able to achieve the following:

1. To acquire skills allowing the student to identify and apply formulas of optics and wave physics using course literature.
2. To be able to identify and illustrate physical concepts and terminology used in optics and to be able to explain them in appropriate detail.
3. To be able to make approximate judgments about optical and other wave phenomena when necessary.
4. To acquire skills allowing the student to organize and plan simpler laboratory course experiments and to prepare an associated oral and written report.
5. To have basic knowledge of Quantum Mechanics and Semiconductors.

#### Unit 1:

Mechanical and electrical simple harmonic oscillators (characteristics and energy), damped harmonic oscillator, forced mechanical and electrical oscillators, impedance.

#### Unit 2:

Transverse wave on a string, the wave equation on a string, harmonic waves, reflection and transmission of waves at a boundary, standing waves and their eigen frequencies, longitudinal waves and the wave equation for them, acoustics waves (Newton formula and Laplace correction).

#### Unit 3:

Huygens' principle, superposition of waves and interference of light by wave front splitting and amplitude splitting; Young's double slit experiment, fringes with white light, interference in parallel thin films, Newton's rings, Fraunhofer diffraction from a single slit & N- slits, Rayleigh criterion for limit of resolution and its application to vision; Diffraction gratings and their resolving power.

#### Unit 4:

Einstein's theory of matter radiation interaction and A and B coefficients; amplification of light by

# Course Structure & Syllabus of B.Tech.– Civil Engineering

## Applicable for Batch: 2020-24

population inversion, components of LASER and pumping methods (in brief), different types of lasers: gas lasers (He-Ne), solid-state laser (ruby)

### Unit 5:

Wave nature of particles, Phase velocity, wave-packet and group velocity, Uncertainty principle and its applications, time-dependent and time-independent Schrodinger equation, physical significance of wave function., Solution of stationary-state Schrodinger equation for one dimensional problem–particle in a box, potential barrier.

### Textbook(s)

1. N. K Bajaj, Physics of Waves and Oscillations, Tata McGraw-Hill, 2008
2. Ajoy Ghatak, Optics, McGraw Hill Education, 2017.
3. D. J. Griffiths, Quantum mechanics, Pearson Education, 2015.

### Reference Books

1. H. J. Pain, The physics of vibrations and waves, Wiley, 2008
2. E. Hecht, Optics, Pearson Education, 2008

S.NO.	LIST OF EXPERIMENTS
1	(a) To determine wavelength of sodium light using Newton's Rings. (b) To determine the refractive index of a liquid using Newton's Rings.
2	To determine wavelength of sodium light using Fresnel's Biprism.
3	(a) To determine wavelength of prominent lines of mercury using plane diffraction grating. (b) To determine the dispersive power of a plane transmission diffraction grating.
4	To determine the specific rotation of cane sugar solution using bi-quartz polarimeter
5	To study the diffraction pattern of Single slit and hence determine the slit width.
6	(a) To verify cosine square law (Malus Law) for plane polarized light. (b) To study the nature of polarization using a quarter wave plate.
7	To study the variation of refractive index of the material of the prism with wavelength and to verify Cauchy's dispersion formula
8	(a) To study photoelectric effect and determine the value of Planck's constant. (b) To verify inverse square law using photocell.
9	To determine the frequency of AC mains using sonometer.
10	To determine the frequency of AC mains or of an electric vibrator by Melde's experiment
11	To measure the numerical aperture (NA) of an optical fiber.

# **Course Structure & Syllabus of B.Tech.– Civil Engineering**

## **Applicable for Batch: 2020-24**

### **11. Teaching and Learning Strategy**

All materials (ppts, assignments, labs, etc.) will be uploaded in Moodle. Assignments, Class Tests etc. will be done. Various teaching methods like Discussion Method, and Lecture Method will be adopted.

# Course Structure & Syllabus of B.Tech.– Civil Engineering

## Applicable for Batch: 2020-24

1. Department offering the course	Physics
2. Course Code	PYF102
3. Course Title	Introduction to Mechanics
4. Credits (L:T:P:C)	3:1:2:5
5. Contact Hours (L:T:P)	3:1:2
6. Prerequisites (if any)	NIL
7. Course Basket	Core Sciences

### 1. Course Objectives

Mechanics lies at the foundation of physics and along with an appreciation of the molecular structure of matter exposes the student to the phenomenology of physics.

### 2. Course Outcomes

**On successful completion of the course, students will be able to achieve the following:**

1. To know Newton's laws of motion, potentials, conservation of energy, momentum and angular momentum, and be able to apply them to projectiles, circular motion, and gravity
2. Demonstrate an understanding of intermediate mechanics topics such as co-ordinate transformations, oscillatory motion, gravitation etc.
3. Demonstrate rigid body and rotational dynamics using the concept of angular velocity and Momentum.
4. Understand the concept of non-inertial frames of reference, coriolis and centripetal accelerations and their applications.
5. Understand the concept of elastic constants and demonstrate bending of beams.

### 3. Curriculum Content

#### Unit 1:

Transformation of scalars and vectors under Rotation transformation; Newton's laws and its completeness in describing particle motion, Cylindrical and spherical coordinates Mechanics of a system of particles, conservation of laws of linear momentum, angular momentum and mechanical energy, centre of mass and equation of motion, Constraints and degrees of freedom.

#### Unit 2:

Potential energy function;  $F = -\text{Grad } V$ , Equipotential surfaces and meaning of gradient; Conservative and non-conservative forces, curl of a force field; Central forces; Conservation of Angular Momentum and areal velocity; Elliptical, parabolic and hyperbolic orbits

#### Unit 3:

Non-inertial frames of reference; Rotating frames of reference, Coriolis force; Applications: Weather systems, projectile motion

#### Unit 4:

Harmonic oscillator; Damped harmonic motion – over-damped, critically damped and lightly-damped

# Course Structure & Syllabus of B.Tech.– Civil Engineering

## Applicable for Batch: 2020-24

oscillators; Forced oscillations and resonance, Kater's Pendulum and bar pendulum.

### Unit 5:

Rotation of rigid body, Moment of Inertia, Torque, angular momentum, kinetic energy of rotation, Theorems of perpendicular and parallel axis, Moment of Inertia of rectangular rod, spherical and cylindrical bodies. Acceleration of a body moving on horizontal and inclined plane. Moment of inertia of Fly Wheel.

### Unit 6:

Elastic constants- Introduction and relationship between elastic constants, Cantilever, Beam, Bending of beam, Twisting of a cylindrical body.

### Textbook(s)

1. Mechanics – D.S. Mathur, S. Chand & Co., 2012.
2. Introduction to Mechanics –D.Kleppner&R.Kolenkow, Cambridge University Press, 2017

### Reference Books

1. Analytical Mechanics, G.R. Fowles and G.L. Cassiday., Cengage Learning India Pvt. Ltd., 2006
2. Introduction to Special Relativity, R. Resnick, John Wiley and Sons, 2007
3. Principles of Mechanics — J.L. Synge & B.A. Griffiths, Andesite Press, 2015

SR.NO.	LIST OF EXPERIMENTS
1	To measure internal diameter, external diameter and depth of a vessel using vernier calipers
2	To measure density of a wire using screw gauge.
3	To determine the Moment of Inertia of a Flywheel
4	To determine Coefficient of Viscosity of water by Capillary Flow Method (Poiseuille's method)
5	To determine the Modulus of Rigidity of a Wire by Maxwell's needle
6	To determine the elastic Constants of a wire by Searle's method
7	To determine the value of g using Bar Pendulum
8	To measure the Young's Modulus using Bending of Beam
9	To determine the value of g using Kater's Pendulum
10	To determine the moment of inertia of a body using Torsion pendulum

# **Course Structure & Syllabus of B.Tech.– Civil Engineering**

## **Applicable for Batch: 2020-24**

#### **4. Teaching and Learning Strategy**

All materials (ppts, assignments, labs, etc.) will be uploaded in Moodle. Assignments, Class Tests etc. will be done. Various teaching methods like Discussion Method, and Lecture Method will be adopted.

# Course Structure & Syllabus of B.Tech.– Civil Engineering

## Applicable for Batch: 2020-24

1. Department offering the course	Physics
2. Course Code	PYF104
3. Course Title	Introduction to Electromagnetic Theory
4. Credits (L:T:P:C)	3:1:2:5
5. Contact Hours (L:T:P)	3:1:2
6. Prerequisites (if any)	NIL
7. Course Basket	Core Sciences

### 8. Course Summary

### 9. Course Objectives

To teach students the effects of electric charges at rest and in motion. Both positive and negative charges produce force field which is called “electric field”. Moving charges produce current, which gives rise to another force field called “magnetic field”. The electromagnetic theory studies the behavior of the electric and magnetic fields.

### 10. Course Outcomes

On successful completion of the course, students will be able to achieve the following:

1. The use of Coulomb's law and Gauss' law for the electrostatic force
2. The relationship between electrostatic field and electrostatic potential
3. The use of the Lorentz force law for the magnetic force
4. The use of Ampere's law to calculate magnetic fields
5. The use of Faraday's law in induction problems
6. The basic laws that underlie the properties of electric circuit elements

### Unit 1: Electrostatics in vacuum

Calculation of electric field and electrostatic potential for a charge distribution; Divergence and curl of electrostatic field; Gauss law and its applications, Laplace's and Poisson's equations; Practical examples like Faraday's cage and coffee-ring effect; energy of a charge distribution and its expression in terms of electric field.

### Unit 2: Electrostatics in a linear dielectric medium

Electrostatic field and potential of a dipole. Bound charges due to electric polarization; Electric displacement; gauss law in dielectrics; Polarization vector, solving simple electrostatics problems in presence of dielectrics – Point charge at the centre of a dielectric sphere, charge in front of a dielectric slab, dielectric slab and dielectric sphere in uniform electric field. Energy in dielectrics system

### Unit 3: Magnetostatics

Electric current and current density, magnetic force, continuity equation, Bio-Savart law and its applications (straight wire and solenoid), Divergence and curl of static magnetic field; Ampere circuital law and its applications ( wire, solenoid & toroid), current loop as magnetic dipole and dipole moment, Para, dia and ferro magnetic materials (properties only)

# Course Structure & Syllabus of B.Tech.– Civil Engineering

## Applicable for Batch: 2020-24

### Unit 4: Faraday's law

Faraday's law in terms of EMF produced by changing magnetic flux; equivalence of Faraday's law and motional EMF; Lenz's law; Electromagnetic braking and its applications; Differential form of Faraday's law expressing curl of electric field in terms of time-derivative of magnetic field and calculating electric field due to changing magnetic fields in quasi-static approximation; energy stored in a magnetic field.

### Unit 5: Displacement current, Magnetic field due to time-dependent electric field and Maxwell's equations

Concept of displacement current, Modifying equation for the curl of magnetic field to satisfy continuity equation; and magnetic field arising from time-dependent electric field; Maxwell's equation in integral and differential form in vacuum and non-conducting medium; transverse nature of EM wave, Wave equation in free space, Wave propagation in conducting medium and non conducting medium & skin depth, Flow of energy and Poynting vector.

### Textbook(s)

1. David Griffiths, Introduction to Electrodynamics, PHI Learning, 2012.

### Reference Books

1. Halliday and Resnick, Physics, Wiley, 2013.
2. W. Saslow, Electricity, Magnetism and Light, Academic Press, 2002.

SR.NO.	LIST OF EXPERIMENTS (ANY TEN)
1	Identification of various electronic components.
2	Use of multimeter for testing diodes, LEDs, transistors and measurements of resistance, capacitance, inductance, dc voltage, dc current, ac voltage, ac current and frequency of ac mains.
3	Charging and discharging of capacitor through resistance and determination of time constant.
4	To determine the specific resistance of a given wire using Carey Foster's bridge.
5	To verify Stefan's law by electrical method.
6	To study the variation of magnetic field with distance along the axis of a current carrying coil and determination of radius of the coil.
7	To calibrate the given voltmeter using potentiometer.
8	To calibrate the given ammeter using potentiometer.
9	To determine the bandgap of a semiconductor p-n junction.
10	To determine the resistance of a sample using four probe method.



# **Course Structure & Syllabus of B.Tech.– Civil Engineering**

## **Applicable for Batch: 2020-24**

11	To determine the band gap of semiconductor using four probe method.
12	To determine a unknown resistance using Wheatstone bridge.

### **11. Teaching and Learning Strategy**

All materials (ppts, assignments, labs, etc.) will be uploaded in Moodle. Assignments, Class Tests etc. will be done. Various teaching methods like Discussion Method, and Lecture Method will be adopted.

# Course Structure & Syllabus of B.Tech.– Civil Engineering

## Applicable for Batch: 2020-24

1. Department offering the course	Department of Chemistry
2. Course Code	CHF101
3. Course Title	Engineering Chemistry
4. Credits (L:T:P:C)	3:1:1:5
5. Contact Hours (L:T:P)	3:1:2
6. Prerequisites (if any)	NIL
7. Course Basket	Core Science Elective

8. **Course Summary:** It covers fundamentals of Chemistry required for the engineering students.

9. **Course Objectives:** The objective of the course is to provide a summery on water treatment, Fuels, green chemistry and synthetic chemistry. The course is specifically designed for CSE& IT students to give them an overview of the working principles, mechanisms, reactions and applications of the building blocks of batteries, cells and surface coatings to protect the metal.

### 10. Course Outcomes:

At the end of the course student will get:

CO1: To understand about the treatment of water, sewage water and hardness related calculations.

CO2: An overview of of the working principles, mechanism of reactions and applications of cells, electrodes and batteries.

CO3: An overview of different types, mechanism of corrosion its prevention and surface coatings.

CO4: The concept of different types of fuel, lubricants. They will understand about their applications in various industries and also about latest development in the field of alternative fuels.

CO5: aware of how chemical processes can be designed, developed and run in a sustainable way. Students acquire the competence to think of chemistry as a sustainable activity.

### 11. Curriculum Content:

#### Unit 1: Water Treatment and Analysis

(08 Lectures)

Standards for drinking water, Water Quality parameters, Determination of alkalinity of water, Hardness of water: Units and determination. Demineralization of water, softening of water: Lime-soda Process, Ion exchange process, Zeolite process and RO process. Internal conditioning methods: Carbonate conditioning, Phosphate conditioning, Colloidal conditioning, Calgon conditioning. Desalination of brackish water

#### Unit 2: Electrochemistry

(06 Lectures)

Migration of ions, Transference number, Determination of Transference number by Hittorf's method, Conduct metric titrations, Types of electrode: Calomel and glass electrode, Battery.

# **Course Structure & Syllabus of B.Tech.– Civil Engineering**

## **Applicable for Batch: 2020-24**

### **Unit 3: Corrosion**

**(06 Lectures)**

Corrosion and its economic aspects, Types of corrosion: Galvanic, Erosion, Crevice, Pitting, Waterline, Soil, Microbiological. Theories of corrosion: Acid, Direct Chemical attack, Electrochemical. Corrosion prevention by metallic, organic/inorganic coatings and corrosion inhibitors

### **Unit 4: Fuels, Lubrication**

**(08 Lectures)**

Classification of fuels, Calorific value, Cetane number, Octane number, fuel quality, Comparison of solid, liquid and gaseous fuel, properties of fuel, alternative fuels: Biofuels, Power alcohol, Introduction of Lubricants, Functions of Lubricants, Classification of lubricants, Mechanisms of Lubrication, Properties of Lubricants.

### **Unit 5: Green Chemistry**

**(08 Lectures)**

Emergence of green chemistry, twelve principle of green chemistry, Use of alternative Feedstock (biofuels), Use of innocuous reagents, use of alternative solvents, design of safer chemicals, designing alternative reaction methodology, minimizing energy consumption

#### **Text Books Recommended:**

1. Engineering Chemistry by Shikha Agarwal. Cambridge University Press Edition 2015.
2. Engineering Chemistry by S. Vairam & Suba Ramesh. Wiley India Pvt. Ltd. 2014.

#### **Reference Books:**

1. Environmental Chemistry by Stanley E. Manahan. CRC Press Taylor and Francis.
2. Organic Chemistry by Morrison and Boyd. Pearson.
3. Physical Chemistry by Atkins. Oxford University Press.
4. Concise Inorganic Chemistry by J.D. Lee. Oxford University Press.

#### **LIST OF PRACTICALS**

1. Determination of alkalinity in the given water sample.
2. Estimation of temporary and permanent hardness in water sample using EDTA as standard solution.
3. Calculation of percentage of available chlorine in bleaching powder.
4. Chloride content in the given water sample by Mohr's method.
5. Determination of iron content in the given ore by using external indicator
6. pH-metric titration.
7. Proximate Analysis of coal sample
8. Flash and Fire point determination of a Lubricant
9. To determine the DO in a given water sample
10. Viscosity of a lubricant by Redwood Viscometer

#### **12. Teaching and Learning Strategy**

All materials (ppts, assignments, labs, etc.) will be uploaded in Moodle. Refer to your course in Moodle for details.

# Course Structure & Syllabus of B.Tech.– Civil Engineering

## Applicable for Batch: 2020-24

1. Department offering the course	Department of Chemistry
2. Course Code	CHF102
3. Course Title	Applied Engineering Chemistry
4. Credits (L:T:P:C)	3:1:1:5
5. Contact Hours (L:T:P)	3:1:2
6. Prerequisites (if any)	NIL
7. Course Basket	Core Science Elective

8. **Course Summary:** It covers fundamentals of Chemistry required for the engineering students.

9. **Course Objectives:** The objective of the course is to provide a summary on water treatment, Fuels, green chemistry and synthetic chemistry. The course is specifically designed for non CSE students to give them an overview of the working principles, mechanisms, reactions and applications of the building blocks of batteries, cells and surface coatings to protect the metal.

### 10. Course Outcomes:

At the end of the course student will get:

CO1: To understand about the treatment of water, sewage water and hardness related calculations.

CO2: An overview of electrical properties of the metals and detailed knowledge of semiconductors.

CO3: The basic fundamental behind selection of engineering materials and their properties required depending on their applications.

CO4: The concept of different types batteries and their applications.

CO5: Aware of how chemical processes can be designed, developed and run in a sustainable way. Students acquire the competence to think of chemistry as a sustainable activity.

### 11. Curriculum Content:

#### Unit 1 Water Technology (08 Lectures)

Standards for drinking water, Water Quality parameters, Demineralization of water, softening of water: Lime-soda Process, Ion exchange process, Zeolite process and Reverse Osmosis process. Internal conditioning methods: Carbonate conditioning, Phosphate conditioning, Colloidal conditioning, Calgon conditioning, Desalination of brackish water, sterilization of water.

#### Unit 2 Conductivity of solids (06 Lectures)

Introduction, Electrical properties of solids, Band theory of solids, Types of energy bands, Application of band theory to solids, Elemental semiconductors, Non-elemental semiconductors, Non-stoichiometric n-type semiconductors, Chalcogen semiconductors

#### Unit 3 Engineering Materials (10 Lectures)

Introduction of polymers; Classification of Polymers; Functionality; Mechanism of Polymerization; Plastics; Individual Polymers; LDPE, HDPE, PVC, Polystyrene, Bakelite, Teflon, PMMA, PET,

# **Course Structure & Syllabus of B.Tech.– Civil Engineering**

## **Applicable for Batch: 2020-24**

Nylon-6, Rubbers (BUNA-S and BUNA-N); Specialty Polymers (Conducting Polymers, Silicones and Polycarbonates), Gypsum, Plaster of Paris, Insulating Materials

### **Unit 4 Battery Technology (06 Lectures)**

Battery, Photovoltaic cell, Metal-air battery, Lithium and nickel battery

### **Unit 5 Green Chemistry (08 Lectures)**

Emergence of green chemistry, Twelve principle of green chemistry, Use of alternative Feedstock (biofuels), Use of innocuous reagents, use of alternative solvents, design of safer chemicals, designing of alternative reaction methodology, minimizing energy consumption.

### **Text Books Recommended:**

1. Engineering Chemistry by Shikha Agarwal. Cambridge University Press Edition 2015.
2. Engineering Chemistry by S. Vairam&Suba Ramesh. Wiley India Pvt. Ltd. 2014.

### **Reference Books:**

1. Environmental Chemistry by Stanley E. Manahan. CRC Press Taylor and Francis.
2. Organic Chemistry by Morrison and Boyd. Pearson.
3. Physical Chemistry by Atkins. Oxford University Press.
4. Concise Inorganic Chemistry by J.D. Lee. Oxford University Press.

### **LIST OF PRACTICALS**

1. Determination of alkalinity in the given water sample.
2. Estimation of temporary and permanent hardness in water sample using EDTA as standard solution.
3. Calculation of percentage of available chlorine in bleaching powder.
4. Chloride content in the given water sample by Mohr's method.
5. Determination of iron content in the given ore by using external indicator
6. pH-metric titration.
7. Proximate Analysis of coal sample
8. Flash and Fire point determination of a Lubricant
9. To determine the DO in a given water sample
10. Viscosity of a lubricant by Redwood Viscometer

### **12. Teaching and Learning Strategy**

All materials (ppts, assignments, labs, etc.) will be uploaded in Moodle. Refer to your course in Moodle for details.

# Course Structure & Syllabus of B.Tech.– Civil Engineering

## Applicable for Batch: 2020-24

1. Department offering the course	Mathematics
2. Course Code	MAF101
3. Course Title	ENGINEERING MATHMATICS-I
4. Credits (L:T:P:C)	3:1:0:4
5. Contact Hours (L:T:P)	3:1
6. Prerequisites (if any)	NIL
7. Course Basket	Core Sciences

**OBJECTIVE:** To introduce the fundamentals in Differential, Integral and Vector Calculus relevant to engineering applications.

### Unit I

Review of Limit, Continuity and differentiation, Successive Differentiation, Leibnitz theorem

(without proof), Problems based on Leibnitz's theorem, Maclaurin's series in one variable, Taylor's expansion in one variable, Asymptote & Curvature, Point of inflexion, Double Points, Cusp, Node and conjugate points, Curve tracing for Cartesian curves.

### Unit II

Partial differentiation and problems, Euler's theorem and its proof, Problems based on Euler's

theorem, Few corollaries on Euler's theorem for higher order derivatives and problems based on them, Taylor's expansion of a function in two variables, Jacobians, its properties, and transformations of coordinates, Maxima and minima of a function in two variables, Method of Lagrange's multipliers and problems.

### Unit III

Double and triple integrals, Change of order of integration, Change of variables, Application of integration to lengths, Surface, areas and Volumes- Cartesian and Polar coordinates. Beta and Gamma functions, Dirichlet's integral and its applications.

### Unit IV

Scalar and Vector fields, Vector differentiation, Directional derivatives Gradient, Divergence

and curl and their physical significance. Evaluation of Line integral, Green's theorem in plane (without proof), Stokes theorem (without proof), Gauss Divergence theorem (without proof) and problems based on them.

**LEARNING OUTCOME:** Students will be able to:

# **Course Structure & Syllabus of B.Tech.– Civil Engineering**

## **Applicable for Batch: 2020-24**

- Use techniques for determining area under a curve, extrema of functions and their use in drawing graphs.
- Compute partial derivatives of functions of two or more variables and use them for determining extrema, saddle points of the surfaces of given functions.
- Use vector calculus in determining motions of fluids, work done by a force etc..
- Theorems like Greens theorem, Diverges theorem, Stocks theorem and their applications in determining surface area and volume.

### **Text Books:**

1. G. B. Thomas Jr. & R. L. Finney, Calculus and Analytic Geometry, 9th Edition, Pearson Education
2. R. K. Jain and S.R.K. Iyenger, Advanced Engineering Mathematics, 2nd edition, Narosa Publishing House, New Delhi, India,2006

### **Reference Books:**

1. E. Kreyszig, Advanced Engineering Mathematics, 9th Edition, John Wiley & Sons, U.K., 2006.

# Course Structure & Syllabus of B.Tech.– Civil Engineering

## Applicable for Batch: 2020-24

1. Department offering the course	Mathematics
2. Course Code	MAF102
3. Course Title	ENGINEERING MATHMATICS-II
4. Credits (L:T:P:C)	3:1:0:4
5. Contact Hours (L:T:P)	3:1
6. Prerequisites (if any)	NIL
7. Course Basket	Core Sciences

**OBJECTIVE:** To introduce the fundamentals in Matrices and Linear Algebra, Ordinary Differential Equations, Laplace Transform and Infinite Series relevant to engineering applications.

### UNIT I

Elementary row operations, row reduced Echelon form, rank of a matrix, invertible matrices,

Consistency of linear system of equations and their solution, Linear independence and dependence of vectors, Vector Spaces and its basis, Linear Transformations, Eigenvalues and Eigenvectors, Cayley-Hamilton Theorem, Diagonalization of matrices.

### UNIT II

Order, degree of ODE and some basic concepts such as linearity and nonlinearity, general so-

lution and particular solution, formation of ODEs, First order differential equation: variable separable method, homogeneous method, and its variants, Linear differential equation of second order with constant coefficients: Complementary function and particular integral for some standard functions, Cauchy Euler linear differential equation, Solution of second order linear differential equation with variable coefficients, method of variation of parameters, solution of simultaneous linear differential equations.

### UNIT III

Laplace transform of some standard functions, Properties of Laplace transform, Inverse Laplace

transforms, Properties of Inverse Laplace transforms, using partial fractions for inverse Laplace transforms, Convolution theorem (without proof), Application of Laplace transforms to solve various types of differential equation, e.g., differential equations with constant coefficient, variable coefficients, simultaneous differential equations.

### UNIT IV

Introduction to sequence and series, series of positive terms, comparison test, D'Alembert's ratio test, Root Test, Alternating series, Leibnitz test. Fourier series of periodic functions, Euler's formulae,



# **Course Structure & Syllabus of B.Tech.– Civil Engineering**

## **Applicable for Batch: 2020-24**

functions having arbitrary period, change of intervals, even and odd functions, half range sine and cosine series.

### **Outcome: Students will be able to:**

- Differentiate between invertible and singular matrices, determine characteristic equations of a matrix and hence eigen values and eigen vector for a given matrix.
- Determine differential equations satisfied by various physical application and their solutions.
- Use properties of improper integrals to define Laplace Transforms and use them to solve initial value physical problems
- Mathematically deal with infinite series and test their convergence.

### **Text Books:**

1. R. K. Jain & S. R. K. Iyenger, Advanced Engineering Mathematics, 2nd Edition, Narosa Publishing House, New Delhi, India, 2006.
2. E. Kreyszig, Advanced Engineering Mathematics, 9th Edition, John Wiley & Sons, U.K., 2006.

### **Reference Books:**

1. W. E. Boyce and R. Di Prima, Elementary Differential Equations, (8th Edition), John Wiley & Sons, U.K., (2005).
2. B. S. Grewal, Higher Engineering Mathematics, 42nd Edition, Khanna Publication, New Delhi, India, 2012

# Course Structure & Syllabus of B.Tech.– Civil Engineering

## Applicable for Batch: 2020-24

1. Department offering the course	Mathematics
2. Course Code	MAF201
3. Course Title	ENGINEERING MATHMATICS-III
4. Credits (L:T:P:C)	3:1:0:4
5. Contact Hours (L:T:P)	3:1
6. Prerequisites (if any)	NIL
7. Course Basket	Core Sciences

**OBJECTIVE:** Introduce the fundamentals in Complex variable.Solving Partial Differential Equations. Legendre polynomial of first kind with properties.Bessel function of first kind and its properties.

### UNIT I

Series solution of ODE of 2<sup>nd</sup> order with variable coefficient with special emphasis to Legendre and Bessel differential equation by Frobenious method, Legendre polynomial of first kind, Bessel function of first kind and their properties.

### UNIT II

Introduction and formation of Partial Differential Equations, Classification of Partial Differential Equations, Solution of first order linear partial differential equations of the form  $Pp + Qq = R$ , Linear PDE with constant coefficients of II<sup>nd</sup> order. Method of separation of variables, Solution of wave equation in one dimension, Solution of heat in one dimension and Laplace equation using method of separation of variables.

### UNIT III

Concept of Limit, continuity, and differentiability, Analytic functions, C-R equations and harmonic functions, Line integral in the complex plane, Cauchy's integral theorem, Cauchy's integral formula for derivatives of analytic function. Representation of a function by power series, Taylor's and Laurent's series, R Singularities, zeroes and poles, Residue theorem, evaluation of real integrals of

$$\text{type } \int_0^{2\pi} f(\cos \theta, \sin \theta) d\theta \text{ and } \int_{-\infty}^{\infty} f(x) dx .$$

### UNIT III

Fourier integral; Fourier transform; Fourier sine and cosine transform; linearity, scaling, frequency shifting and time shifting properties; convolution theorem. Z-transform; properties of Z-transforms; Convolution of two sequences; inverse Z-transform. Applications of Fourier Transform and Z-Transform.

**Outcome:** The student will be able to use

# **Course Structure & Syllabus of B.Tech.– Civil Engineering**

## **Applicable for Batch: 2020-24**

- Familiarity with methods to solve partial differential equations.
- Differentiation and Integration of complex functions to physical problems.
- Complex integration for solving real integrals.
- Fourier and Z-transform rules to physical problems.

### **Text Books:**

1. J.W. Brown & R. V. Churchill: Complex Variables & Applications, 9<sup>th</sup> edition, McGraw-Hill, 2013.
2. R. K. Jain & S. R. K. Iyenger, Advanced Engineering Mathematics, 2<sup>nd</sup> Edition, Narosa Publishing House, New Delhi, India, 2014.

### **Reference Books:**

1. B. S. Grewal, Higher Engineering Mathematics, 42<sup>th</sup> Edition, Khanna publication, New Delhi, India, 2012.
2. E. Kreyszig, Advanced Engineering Mathematics, 9<sup>th</sup> Edition, John Wiley & Sons, U.K., 2006.

# **Course Structure & Syllabus of B.Tech.– Civil Engineering**

## **Applicable for Batch: 2020-24**

1. Department offering the course	Mathematics
2. Course Code	MAF202
3. Course Title	Probability and Statistics
4. Credits (L:T:P:C)	3:1:0:4
5. Contact Hours (L:T:P)	3:1
6. Prerequisites (if any)	NIL
7. Course Basket	Core Sciences

**OBJECTIVE:** The objectives of the course are to familiarize the students with statistical techniques, to equip them with standard concepts and, to learn tools of probability theory to solve engineering problems.

### **Unit I: Descriptive Statistics and Probability**

Review of mean, median and mode, variance. Moments and properties, Skewness and Kurtosis. Probability: concepts, definition, examples, conditional probability and Bayes' theorem.

### **Unit II: Random Variables and Probability Distributions**

Discrete & continuous random variables and their properties, mass function, density function, distribution functions. Expectation, moment generating function, Binomial, Poisson, Exponential & Normal distributions and their applications.

### **Unit III: Correlation and Regression**

Bivariate distributions and their properties, Joint and marginal density functions, Conditional densities. Covariance, Correlation, Regression, Regression lines. Curve fitting by the method of least square- fitting of straight lines.

### **Unit IV: Hypothesis Testing**

Population and samples, Sampling distribution of statistic, standard error. Null and Alternative Hypothesis, critical region, critical values and level of significance. One tail and two-tail tests, confidence interval, Errors in testing of hypothesis; Type I and Type II errors, power of the test.

### **Unit V: Inferential test procedures**

Test of significance, large sample test for single proportion, difference of proportion, single mean, difference of means and difference of standard deviation. Small sample test: Student's t-test and its applications, F-test and its applications. Chi-square test for goodness of fit and independence of attributes.

# **Course Structure & Syllabus of B.Tech.– Civil Engineering**

## **Applicable for Batch: 2020-24**

**LEARNING OUTCOME:** Students will be able to:

- Compute probability, various discrete and continuous probability distributions of random variables and their properties.
- Use the tools of statistics including measures of central tendency, correlation and regression.
- Use statistical methods for studying data samples.
- Use large sample and small sample tests.

**Text Books:**

1. S. Palaniammal, Probability and Random Processes, PHI learning private ltd., 2015.
2. S.C. Gupta, Fundamentals of Statistics, 7th Ed., Himalaya Publishing House, 2018.

**Reference Books:**

1. S.C. Gupta, V.K. Kapoor, Fundamentals of Mathematical Statistics, Sultan Chand & Sons, 2016.
2. Richards A Jonson, Irvin Miller and Johnson Freund, Probability and Statistics for Engineering, 9th Edition, PHI, 2011.
3. S. Ross, A First Course in Probability, 8th Ed., Pearson Education India, 2010.
4. M.R. Spiegel, J.J. Schiller and R.A. Srinivasan, Probability and Statistics, Schaum's Outlines, 2013.

# Course Structure & Syllabus of B.Tech.– Civil Engineering

## Applicable for Batch: 2020-24

1.	<b>Department offering the course</b>	Civil Engineering
2.	<b>Course Code</b>	CEF201
3.	<b>Course Title</b>	Fluid Mechanics
4.	<b>Credits</b>	4
5.	<b>Contact Hours (L:T:P)</b>	2 1 2
6.	<b>Prerequisites (if any)</b>	None
7.	<b>Course Basket</b>	Discipline Core

**8. Course Summary:** Fluid mechanics covers the fundamental study about the flow characteristics.

### 9. Course Objectives:

The course is designed to gain knowledge regarding the flow characteristics and its effects on the Civil Engineering Structures.

### 10. Course Outcomes:

On completion of this course, the students will be able to

1. Calculate Hydrostatic forces on bodies by applying concepts of fluid properties.
2. Apply knowledge of Fluid statics and Fluid dynamics in CFD analysis.
3. Compute major and minor losses in pipe and water hammer pressure.
4. Apply Knowledge of Model laws and Dimensional analysis.
5. Measure discharge through Notches and Orifices.

### 11. Curriculum Content:

#### Unit 1

#### Fluid Properties and Hydrostatics

Introduction to Fluid Mechanics, Definition of Fluid, Solid and Fluid Continuum. Definition, Units and dimensions of Mass density, Specific weight, Specific Volume, Relative density, Viscosity, Capillarity & Surface Tension. Newton's law of viscosity, Equation for capillarity. Definition of Pressure, Hydrostatic pressure equation, Absolute and Gauge pressures. Measurement of Pressure, Force exerted by a liquid on a flat surface, concept of buoyancy.

#### Unit 2

#### Kinematics and Dynamics of Fluid Flow

Introduction, Classification of flow, Three dimensional continuity equation (Cartesian coordinates), General Continuity equation, Stream function, Velocity potential, Stream line, Equipotential line, (Two dimensional only). Concept of inertia force and forces causing motion. Derivation of Euler's equation & Bernoulli's equation with assumptions and limitations, problems on application of Bernoulli's equation

#### Unit 3

#### Flow through Pipes

Introduction, Reynolds's number and its significance, Laminar and Turbulent Flow, Hagen-poiseuille's equation, Major and minor losses in pipe flow Equation for head loss due to friction (Darcy's), Equation for head loss due to sudden expansion. Pipes in series, pipes in parallel and equivalent pipes, Water Hammer in pipes.

#### Unit 4

#### Dimensional Analysis and Model Studies

Introduction to Dimensional analysis, Units and dimensions, Dimensional Homogeneity. Raleigh's and Buckingham's methods of analysis, Model studies, similitude, dimensional parameters, Types of models, Froude's models: Reynold's models

#### Unit- 5

# **Course Structure & Syllabus of B.Tech.– Civil Engineering**

## **Applicable for Batch: 2020-24**

### **Flow Measurements**

Introduction, Equation for discharge over triangular notch, Rectangular notch, Trapezoidal notch. Classification of orifices, Hydraulic coefficients of an orifice, Problems on Vertical Orifice.

### **List of Experiments**

1. Verification of Bernoulli's theorem.
2. Determination of metacentric height.
3. Determination of coefficient of discharge for rectangular notch.
4. Determination of coefficient of discharge for triangular notch.
5. Determination of coefficient of discharge for trapezoidal notch.
6. Determination of coefficient of discharge for Venturimeter.
7. Determination of coefficient of discharge for Orificemeter.
8. Determination of frictional losses in pipe flow.
9. To find Critical Reynolds number for a pipe flow
10. To determine the minor losses due to sudden enlargement, sudden contraction and bends

### **Textbook(s)**

1. Bansal, R. K., "Fluid Mechanics and Hydraulic Machine", Lakshmi Publications, New Delhi., 2008
2. Subramanya. K., "Fluid Fluid Mechanics", Tata McGraw Hill, New Delhi.
3. Rajput, R.K., "A Textbook of Fluid Mechanics and Hydraulic Machines", S. Chand Publications, 6th Edition. 2016

### **Reference Books**

- 1 Modi, P. N., Seth, S. M., "Hydraulics and Fluid Mechanics", Standard Book House, New Delhi, 2004.
- 2 Jain, A.K., "Fluid Mechanics: Including Hydraulic Machines", Khanna Publishers, New Delhi, 2010

### **12. Teaching and Learning Strategy**

All materials (ppts, assignments, labs, etc.) will be uploaded in Moodle. Refer to your course in Moodle for details.

# Course Structure & Syllabus of B.Tech.– Civil Engineering

## Applicable for Batch: 2020-24

1.	Department offering the course	Civil Engineering
2.	Course Code	CEF202
3.	Course Title	Strength of Materials
4.	Credits	4
5.	Contact Hours (L:T:P)	3 0 2
6.	Prerequisites (if any)	None
7.	Course Basket	Discipline Core

8. **Course Summary:** Subject covers the fundamental study about the material characteristics

9. **Course Objectives:** The course objective is to learn the strength behaviour of materials and properties of those materials used in Civil Engineering

### 10. Course Outcomes:

On completion of this course, the students will be able to:

CO1: Calculate uniaxial and biaxial stresses and strains and understand the relationship among elastic constants.

CO2: Analyze different types of statically determinate beams and draw shear force diagrams and bending moment diagrams.

CO3: Determine variation of bending stresses and shear stresses and draw them across various beam sections.

CO4: Calculate deflections and rotations for statically determinate beams subjected to different types of loadings by Macaulay's method.

CO5: Apply Euler's and Rankine's theories in the analysis of columns with different end conditions.

### 11. Curriculum Content:

#### Unit 1

##### Uniaxial and Biaxial Stresses and Strains

**Uniaxial Stresses and Strains:** Properties of Materials, Stress, Strain, Hooke's law, Poisson's Ratio, Stress – Strain diagram for structural steel and nonferrous metals, Principles of superposition, Total elongation of tapering bars of circular and rectangular cross sections. Elongation due to self weight, Volumetric strain, Elastic constants, Relationship among elastic constants.

**Biaxial Stresses and Strains:** Introduction, Principal Stresses and Strains, Stress components on inclined planes, General two dimensional stress system, Principal planes and stresses, Mohr's Circle of stresses.

#### Unit 2

##### Bending Moment and Shear Force in Beams

Introduction, Types of beams, loadings and supports, Shear force and Bending moment, Sign conventions, Relationship between loading, shear force and bending moment, Shear force and bending moment equations, SFD and BMD with salient values for cantilever beams, simply supported beams and overhanging beams for Point loads, UDL, Triangular loads and Couple.

#### Unit 3

##### Bending Stress and Shear Stress in Beams

Introduction – Bending stress in beam, Assumptions in simple bending theory, Derivation of Bernoulli's equation for simple bending, Section modulus, Flexural rigidity, Expression for horizontal shear stress in beam, Shear stress distribution for rectangular, 'I' and 'T' sections.

#### Unit 4

##### Deflection of Beams

Deflection of statically determinate beams by Macaulay's method, Moment area method and Conjugate beam methods.



# **Course Structure & Syllabus of B.Tech.– Civil Engineering**

## **Applicable for Batch: 2020-24**

### **Unit 5**

#### **Elastic Stability of Columns and Torsion**

Elastic stability of columns - Introduction – Short and long columns, Euler’s theory on columns, Effective length, slenderness ratio, radius of gyration, buckling load, Assumptions, derivations of Euler’s Buckling load for different end conditions, Limitations of Euler’s theory, Rankine’s formula and solution of problems –

**Concept of Torsion** - Torsion of circular shafts - torque - twist - shear stress – Solution of simple problems.

#### **List of Experiments**

1. Tension test on Mild and TOR steel.
2. Compression test on different metals.
3. Compression test on Timber (parallel & across the grains).
4. Shear test on Mild steel.
5. Brinell and Rockwell Hardness test on different metals.
6. Impact test on different metals.
7. Bending test on Mild steel.

#### **Text Books**

1. R. Subramanian “Strength of Materials” Oxford University Press, India, ISBN: 9780199464739

#### **References**

1. Timoshenko, S. P., “Elements of Strength of Materials”, East West Press, 2009.
2. Beer, F. P., Johnston, E. R., DE Wolf, J. J. T., “Mechanics of Materials”, The McGraw Hill Companies, 3rd Edition.
3. Basavarajaiah, B. S., Mahadevappa, P., “Strength of Materials”, and Orient Black swan, New Delhi, 2010.
4. Pytel, A., Singer, F. L., “Strength of Materials”, Harper Collins Publications, 1990.
5. Russell C. Hibbeler, Mechanics of materials, Pearson 10th Edition, 2017

### **12. Teaching and Learning Strategy**

All materials (ppts, assignments, labs, etc.) will be uploaded in Moodle. Refer to your course in Moodle for details.

# Course Structure & Syllabus of B.Tech.– Civil Engineering

## Applicable for Batch: 2020-24

1.	<b>Department offering the course</b>	Civil Engineering
2.	<b>Course Code</b>	CEF203
3.	<b>Course Title</b>	Geomatics Engineering
4.	<b>Credits</b>	4
5.	<b>Contact Hours (L:T:P)</b>	2 1 2
6.	<b>Prerequisites (if any)</b>	None
7.	<b>Course Basket</b>	Discipline Core

8. **Course Summary:** Geomatics Engineering covers the entire concepts of surveying and Advanced surveying with the idea of GIS and GPS

9. **Course Objectives:** The course is designed to gain knowledge about surveying and its relevance in mapping and to introduce the students with various methods of calculating areas and volumes using maps.

10. **Course Outcomes:** On completion of this course, the students will be able to:

1. To understand the process of chain surveying and able to determine the lengths for real life engineering projects.
2. To understand the process of compass surveying and able to determine the angles for real life engineering projects.
3. To understand, analyse and perform Theodolite survey for horizontal control and levelling for vertical control in field.
4. To understand the process of Contouring and Triangulation survey and use this concept to solve real engineering projects.
5. To understand the concept of GPS and GIS and use for decision making for any real engineering projects.

### 11. Curriculum Content:

#### Unit 1

**Introduction and Chain surveying:** Types and classification of survey. Principles of surveying. Units of measurement. Scales-types and uses, Maps Chain surveying – Types, difficulties during chain surveying, corrections of chain length, Operation and use of metric chain and tape. Use of ranging rods, cross staff, arrows, pegs etc.

#### Unit 2

**Compass surveying and Vertical Control:** Types of surveying, Bearings - Whole circle and Reduced Bearing -Traversing - Local attraction - Magnetic dip and declination. Bowditch method. Plane table survey and accessories- Radiation, intersection and traversing. Two-point problem, Three-point problem.

Vertical Control- Definitions of terms used in levelling, different types of levels and leveling process, adjustments, bench marks. MSL, height of instrument method, rise and fall method, inverse levelling, and plane of collimation method. Profile levelling, longitudinal and cross sectioning.

#### Unit 3

**Theodolite Survey:** Theodolite- Definition, types, principle and fundamental axes. Temporary adjustments. Measurements of horizontal and vertical angles. Method of repetition and

# **Course Structure & Syllabus of B.Tech.– Civil Engineering**

## **Applicable for Batch: 2020-24**

Reiteration. Finding out height and elevation of object by single and double plane method. Curves: Simple Curve-Elements of simple curves. Designation of a curve. Setting out simple curve Tabulation and setting out of compound curve, reverse curve, transition curve, combined curve and vertical curves. area and volume computations; cross-sections and profiles

### **Unit 4**

**Contouring and Theory of Errors:** Contouring- definition and characteristics of contours. Uses of contours. Methods of contouring-direct and indirect. Errors-Types and sources of errors, theory of least squares, method of weights, method of correlates, angle and station adjustment, figure adjustment. Necessity of Control Surveying, Principle of Triangulation, Classification of Triangulation Systems, Station Marks, Towers and Signals, Satellite station, Reconnaissance, Inter-visibility of stations, Angular Measurement, Base line measurement and its extension

### **Unit 5**

**Astronomical Surveying, GPS and GIS:** Astronomical Surveying – Celestial sphere, Basic terms, Global Positioning System- NAVSTAR GPS system. Advantages of GPS. Components of GPS- Space, control and user segments. Principles of position fixing with GPS. Relative and differential positioning. Factors affecting GPS observations, GPS applications. Geographic Information systems: Components of GIS-Hardware, software and expertise. Benefits and applications of IS. Geographic data- data input, processing –data structures- rasters and vectors, database management-layer concepts, spatial manipulation and analysis and graphical output and visualization – *GNSS and RTK survey methods*

### **List of Experiments**

- 1 Study of different types of maps, their scales, latitude, longitude, colors and symbols
- 2 Finding local attraction at a place
- 3 Calculation of whole circle bearing of a closed area.
- 4 Setting out polygons using prismatic compass; Location of details using compass traversing.
- 5 Method of radiation and intersection by plane tabling.
- 6 Two point and three point problem.
- 7 Finding elevations using dumpy level with change point and using plane of collimation method.
- 8 Finding latitude and departure of a closed area
- 9 Plotting of contours by block levelling.
- 10 Finding horizontal angle by method of repetition, method of reiteration and measurement of vertical angles.
- 11 Finding out height and elevation of an object by single plane method.
- 12 Setting out simple curves by offsets from long chord & chord produced method.
- 13 Setting out simple curves by Rankine's deflection angle method.

### **Text Books**

1. Punmia, B. C., Jain, A. K., "Surveying", Laxmi Publications Pvt. Ltd., New Delhi, Vol. I, 16 th Edition, 2005.
2. Punmia, B. C., Jain, A. K., "Surveying", Laxmi Publications Pvt. Ltd., New Delhi, Vol. II, 15 th Edition, 2005.
3. Engineering Roy, S. K., "Fundamentals of surveying", Prentice Hall of India, New Delhi, 2 nd Edition, 2010.

# **Course Structure & Syllabus of B.Tech.– Civil Engineering**

## **Applicable for Batch: 2020-24**

4. Reddi, M. A., “Remote Sensing and Geographical Information Systems”, BS Publications, 2001.

### **References**

1. Chandra, A. M., “Plane Surveying”, New age International, 2nd Edition, 2006.
2. Beer FP and Johnson ER, “Mechanics for Engineers- Dynamics and Statics”-3rd SI Metric edition, Tata McGraw Hill.-2008
3. De, A., “Plane surveying”, S. Chand and Company Ltd., 2000.
4. Roy S. K., “Fundamental of surveying”, Prentice Hall of India, 2nd Edition, 2010.
5. Chandra, A. M., “Plane Surveying”, New age International, 2nd Edition, 2006.
6. Arora, K.R., “Surveying”, Standard Book House, Delhi, Vol. II & III, 11th Edition, 2010.
7. McCormac, J. C., Sarasua, W., Davis, W., “Surveying”, Wiley India, 6th Edition, 2012.
8. Lillesand, T. M., Kiefer, R.W., Chipman, J. W., “Remote Sensing and Image Interpretation”, John Wiley & Sons Limited, Canada, 5th Edition, 2004.
9. Agor, R., “A Text Book of Surveying and Levelling”, Khanna Publications, Delhi, 11th Edition, Vol. II & III, 2012.

### **12. Teaching and Learning Strategy**

All materials (ppts, assignments, labs, etc.) will be uploaded in Moodle. Refer to your course in Moodle for details.

# Course Structure & Syllabus of B.Tech.– Civil Engineering

## Applicable for Batch: 2020-24

1.	<b>Department offering the course</b>	Civil Engineering
2.	<b>Course Code</b>	CEF204
3.	<b>Course Title</b>	Water Supply Engineering
4.	<b>Credits</b>	4
5.	<b>Contact Hours (L:T:P)</b>	2 1 2
6.	<b>Prerequisites (if any)</b>	None
7.	<b>Course Basket</b>	Discipline Core

8. **Course Summary:** Water Supply Engineering covers the design of community water supply systems.

9. **Course Objectives:** The course provides an understanding of drinking water quality, treatment and design of treatment units, water supply and water connections to households.

### 10. Course Outcomes:

On completion of this course, the students will be able to

1. Various water demand quantities and basic knowledge about drinking water parameters.
2. Treatment of public water supply.
3. Design of water treatment plants and storage capacity of reservoir
- 4: Understanding of various components of house water supply system

### 11. Curriculum Content

#### Unit 1

**Need for public water supply and role of engineers:** Quantity of water, Different water demands, design period and population forecast-Arithmetic mean, Geometric mean and incremental increase method. Sources of water.

#### Unit 2

**Quality of water:** Physical, chemical and bacteriological water quality parameters, Standards of Water quality desired for domestic water supplies – BIS and WHO Standards - Water borne diseases.

#### Unit 3

**Treatment of water:** Objectives. Conventional treatment plant layout. Different treatment units (location and its function) - Screening, Aeration, Sedimentation, Filtration and Disinfection. Concept of flow through treatment units

#### Unit 4

**Storage and distribution of water:** Layouts of distribution systems, Methods of distribution: pressure and gravity distribution systems, concept of service and balancing reservoirs, capacity of distribution reservoirs.

#### Unit 5

**Water supply to buildings:** Components of house water supply system, Pipe sizes and recommended velocities and pressures. Pipe fittings and pipe joints. Valves and taps. Hot water supply, Rainwater harvesting, Fire safety and firefighting installation in buildings.

### Text Books

1. Garg, S. K., “Water Supply Engineering”, Khanna Publishers (RS), New Delhi, 2010.
2. Punmia, B. C., Jain, A. K., “Environmental Engineering-I”, Laxmi Publication (P) Ltd., New Delhi, 2005.

### References

# **Course Structure & Syllabus of B.Tech.– Civil Engineering**

## **Applicable for Batch: 2020-24**

1. Manual on Water Supply and Treatment, CPHEEO, Ministry of Urban Development, Government of India, New Delhi.
2. Panchdhari, A. C., “Water Supply and Sanitary Installations”, New Age International Publishers, New Delhi, 2<sup>nd</sup> Edition, 2000.
3. Nazaroff, W. W., Cohen, A. L., “Environmental Engineering Science”, Wiley India, 2001.

### **List of Experiments**

1. Determination of turbidity, colour and conductivity
2. Determination of pH, alkalinity and acidity
3. Determination of hardness and chlorides
4. Determination of residual chlorine and chlorine demand
5. Determine the fluoride content in drinking water
6. Determine the Nitrate content in drinking water
7. Measurement of sound level with sound level meter

### **12. Teaching and Learning Strategy**

All materials (ppts, assignments, labs, etc.) will be uploaded in Moodle. Refer to your course in Moodle for details.

# Course Structure & Syllabus of B.Tech.– Civil Engineering

## Applicable for Batch: 2020-24

1.	<b>Department offering the course</b>	Civil Engineering
2.	<b>Course Code</b>	CEF205
3.	<b>Course Title</b>	Sewage and Solid Waste Engineering
4.	<b>Credits</b>	4
5.	<b>Contact Hours (L:T:P)</b>	2 1 2
6.	<b>Prerequisites (if any)</b>	Water Supply Engineering
7.	<b>Course Basket</b>	Discipline Core

8. **Course Summary:** Sewage and Solid Waste Engineering covers the design of community sewage conveyance systems, sewage treatment methods and solid waste management.

9. **Course Objectives** The course provides an understanding of drinking water quality, treatment and design of treatment units, water supply and water connections to households.

### 10. Course Outcomes:

On completion of this course, the students will be able to

1. To apply sewage treatment knowledge in various rural and urban city planning.
2. Estimate waste water characteristics.
3. Design of sewerage tanks and pipes for sewers after determining the capacity.
4. Design of sewerage treatment plants based on characteristics.

### 11. Curriculum Content

#### Unit 1

**Introduction:** Introduction, Basic Definitions, Need for waste water collection, Conveyance, Treatment and disposal, Types of sewerage systems, Quantity of sewage, Dry weather flow and factors affecting dry weather flow, Flow variations and their effects on design of sewerage system, Computation of design flow, Street inlets, Catch basins, Manhole and drop manhole

#### Unit 2

**Wastewater Characterization:** Analysis of sewage, Physical, chemical and biological characteristics with emphasis on BOD and COD, Concept of aerobic and anaerobic activity, Sampling, Effluent standards

#### Unit 3

**Treatment of Sewage:** Flow diagram of municipal sewage treatment plant, Primary treatment, Screening, Grit chamber, Skimming tank, Primary sedimentation tank, Design approaches

#### Unit 4

**Secondary Treatment:** Theory and operation of trickling filter and types of trickling filters, Design of single stage trickling filter, Activated sludge process and its modifications, Design aspects of activated sludge process, Sludge digestion, Sludge drying beds, other methods of sludge disposal on site treatment method

#### Unit 5

**Solid Waste Management:** Introduction; source, types, quantity, characteristics of solid wastes. Sampling & analyses of solid wastes. Municipal solid waste management: storage, collection, transfer, and transportation. Treatment & disposal of solid wastes: sanitary land filling, composting, incineration. Typical design problems on solid waste management.

#### List of Experiments

1. Determination of physical characteristics of sewage
2. Determination of Biochemical oxygen demand (BOD) of sewage
3. Determination of COD of sewage

# **Course Structure & Syllabus of B.Tech.– Civil Engineering**

## **Applicable for Batch: 2020-24**

4. Determination of Sulphur content of sewage
5. Case study of quantization of solid waste
6. Determine the density of solid waste

### **TextBook:**

1. Garg, S. K., “Environmental Engineering: Sewage Disposal and Air Pollution Engineering”, Khanna Publishers, New Delhi, 26th Edition (Paperback), Vol. II, 2010.
2. Punamia, B. C., Jain, A. K., “Waste Water Engineering”, Firewall Media, New Delhi, 1998.

### **ReferenceBooks:**

1. Manual on Sewage and Sewerage Treatment, CPHEEO, Ministry of Urban Development, New Delhi

### **12. Teaching and Learning Strategy**

All materials (ppts, assignments, labs, etc.) will be uploaded in Moodle. Refer to your course in Moodle for details.



# Course Structure & Syllabus of B.Tech.– Civil Engineering

## Applicable for Batch: 2020-24

1.	<b>Department offering the course</b>	Civil Engineering
2.	<b>Course Code</b>	CEF206
3.	<b>Course Title</b>	Structural Analysis I
4.	<b>Credits</b>	4
5.	<b>Contact Hours (L:T:P)</b>	2 1 2
6.	<b>Prerequisites (if any)</b>	Strength of Materials
7.	<b>Course Basket</b>	Discipline Core

8. **Course Summary:** Course enables the students on analysis of elements for axial forces and reactions for static as well as moving loads.

9. **Course Objectives:** The course is designed to make students aware about the basic concepts of structural analysis and different design principles used there in

### 10. Course Outcomes:

On completion of this course, the students will be able to

1. Calculate deflection of beams and plane trusses by energy method.
2. Analyze three hinged arches and cables.
3. Apply three moment theorem for analyzing statically indeterminate beams.
4. Determine the support reactions for two hinged parabolic arches and circular arches and draw bending moment diagrams.
5. Draw influence line diagram for shear forces and bending moments for statically determinate and indeterminate beams.

### 11. Curriculum Content:

#### Unit 1

**Deflection of Beams and Plane Trusses by Energy Method:** Castigliano's theorems, Strain energy due to bending and axial load, Unit Load method, Deflection of statically determinate beams and statically determinate plane trusses by energy method and Unit Load method.

#### Unit 2

**Three hinged Arches and Cables:** Three hinged parabolic arches with supports at same and different levels, Determination of normal thrust, radial shear and bending moment, Analysis of cables under point loads and UDL, Length of cables for supports at same and at different levels.

#### Unit 3

**Theorem of Three Moments:** Statically indeterminate structures, Degree of static indeterminacy, stability, Theorem of three moments, analysis of statically indeterminate beams (Propped cantilever beam, fixed beam and continuous beam), sink of support, bending moment diagram and shear force diagram.

#### Unit 4

**Strain Energy Method:** Concept of Strain energy, analysis of statically indeterminate beams, bending moment diagram and shear force diagram, Analysis of two hinged parabolic and circular arches with different types of loadings.

#### Unit-5

**Influence Lines and Moving loads:** Concept of influence lines, ILD for reactions, SF and BM for statically determinate and indeterminate beams, Muller Breslau Principle, ILD for axial forces in determinate trusses, BM, SF and axial forces in determinate systems using ILD, Maximum BM and

# **Course Structure & Syllabus of B.Tech.– Civil Engineering**

## **Applicable for Batch: 2020-24**

SF in determinate beams using rolling loads concepts, Maxwell's reciprocal theorem, Maxwell Betti's theorem.

### **List of Experiments**

1. Redundant Joint Apparatus
2. Elastically Coupled Beam Structure
3. Deflection of Truss Apparatus
4. Three Hinged Arch Apparatus
5. Beam Model
6. Elastic Properties of Deflected Beam Apparatus
7. Column Apparatus
8. Portal Frame Apparatus
9. Curved Member Apparatus

### **Text Books**

1. T. S. Thandavamoorthy "Structural Analysis", Oxford University Press, ISBN: 9780198069188
2. Timoshenko S. P. and Young D. H., Theory of Structures, McGraw – Hill Book Company.

### **References**

1. Norris, C. H., Wilbur, J. B., "Elementary Structural Analysis", International Student Edition, Literary Licensing, LLC, 2012.
2. Reddy, C. S., "Basic Structural Analysis", Tata McGraw Hill, New Delhi, 2011.
3. Ramamrutham, S., Narayan, R., "Theory of Structure", Dhanpat Rai & Co. Ltd.

### **12. Teaching and Learning Strategy**

All materials (ppts, assignments, labs, etc.) will be uploaded in Moodle. Refer to your course in Moodle for details.

# Course Structure & Syllabus of B.Tech.– Civil Engineering

## Applicable for Batch: 2020-24

1.	<b>Department offering the course</b>	Civil Engineering
2.	<b>Course Code</b>	CEF207
3.	<b>Course Title</b>	Concrete Technology
4.	<b>Credits</b>	4
5.	<b>Contact Hours (L:T:P)</b>	3 0 2
6.	<b>Prerequisites (if any)</b>	Strength of Materials
7.	<b>Course Basket</b>	Discipline Core

**8. Course Summary:** In this course students will learn about the concrete and its microstructure, different properties of the concrete in green stage and in hardened stage. Mix designing of the concrete as per Indian standards and various special concretes needs to be produced as per the demands of the market and various industries.

**9. Course Objectives:** The objectives of this course are to learn the design concrete mixes for various mix proportions using different types of blending materials such as silica fume, fly ash and blast furnace slag.

### 10. Course Outcomes:

On completion of this course, the students will be able to

1. Study the microstructure of basic constituents of concrete.
2. Study the behavior of fresh concrete and hardened concrete.
3. Design different types of concrete mixes.
4. Design different types of special concretes

### 11. Curriculum Content:

#### Unit 1

**Concrete Ingredients and Microstructure:** Cement – Chemical composition, hydration of cement, types of cement, manufacture of OPC with flow charts. Tests on cement – field testing, fineness, normal consistency, setting time, soundness, and compressive strength (detailed procedures covered in laboratory). Quality of mixing water. Structure of aggregate phase, structure of hydrated cement paste, structure - property relationship in hydrated cement paste, transition zone in concrete, influence of transition zone on properties of concrete.

#### Unit 2

**Chemical and Mineral Admixtures:** Accelerators-Retarders- Plasticisers- Super plasticizers- Water proofers – Mineral Admixtures like Fly Ash, Silica Fume, Ground Granulated Blast Furnace Slag and Metakaoline -Their effects on concrete properties.

#### Unit 3

**Proportioning of Concrete Mix and Fresh Concrete:** Principles of Mix Proportioning, Properties of concrete related to Mix Design Physical properties of materials required for Mix Design, procedure of mix design as per Indian Standards, numerical examples of mix design. Workability – definition, factors affecting workability, measurement of workability by slump, compaction factor, Vee-Bee, flow tests. Segregation and bleeding, process of manufacture of concrete – batching. Mixing, transporting, placing, compaction, curing of concrete.

#### Unit 4

**Hardened Concrete:** Factors affecting strength, w/c ratio, gel/space ratio, maturity concept, effect of aggregate properties, compressive strength, tensile strength, bond strength, modulus of rupture, modulus of elasticity, Poisson's ratio, relationship between these parameters. Accelerated curing, aggregate- cement bond strength. Shrinkage – plastic shrinkage and drying shrinkage, factors affecting shrinkage. Creep – measurement of creep, factors affecting creep, effect of creep. Durability – definition, significance, permeability, sulphate attack, chloride attack, carbonation, freezing and

# **Course Structure & Syllabus of B.Tech.– Civil Engineering**

## **Applicable for Batch: 2020-24**

thawing. Factors contributing to cracks in concrete – plastic shrinkage, settlement cracks, construction joints. Thermal expansion, transition zone, structural design deficiencies. Tests on hardened concrete – compressive strength, split tensile strength, flexural strength, non-destructive testing of concrete.

### **Unit- 5**

**Special Concretes:** Constituents, Properties and applications of lightweight concrete, self-compacting concrete and fibre reinforced concrete.

### **List of Experiments**

- 1 Normal consistency of cement.
- 2 Initial and final setting time of cement.
- 3 Compressive strength of cement.
- 4 Soundness of cement.
- 5 Tensile strength of cement
- 6 Bulking of sand
- 7 Water absorption of bricks.
- 8 Compressive strength of bricks.
- 9 Workability test: Slump Test and Compaction Factor Test
- 10 Flow Test
- 11 Compressive Strength Test of Hardened Concrete.
- 12 Flexural Strength Test of Hardened Concrete.
- 13 Split Tensile Strength Test of Hardened Concrete.
- 14 Non Destructive Testing of Concrete
- 15 Concrete mixed design as per Indian Standard recommendation guidelines.

### **Textbook(s):**

1. Shetty, M. S., “Concrete Technology”, S. Chand & Co. Ltd, New Delhi, 6<sup>th</sup> Edition, 2005.
2. Mehta, P. K, Monteiro, P. J. M., “Concrete: Microstructure, Properties, and Materials”, McGraw Hill Professional, 2013.
3. Gambhir, M. L., “Concrete Technology”, Tata McGraw Hill, New Delhi, 5<sup>th</sup> Edition, 2013.
4. Neville, A. M., Brooks, J. J., “Concrete Technology”, Prentice Hall, 2<sup>nd</sup> Edition, 2010.

### **Reference Books:**

1. Neville, A. M., “Properties of concrete”, ELBS Publications, London.
2. IS: 10262: “Recommended Guidelines for Concretes Mix design”, BIS Publication.

### **12. Teaching and Learning Strategy**

All materials (ppts, assignments, labs, etc.) will be uploaded in Moodle. Refer to your course in Moodle for details.

# Course Structure & Syllabus of B.Tech.– Civil Engineering

## Applicable for Batch: 2020-24

1.	<b>Department offering the course</b>	Civil Engineering
2.	<b>Course Code</b>	CEF357
3.	<b>Course Title</b>	Hydrology and Irrigation Engineering
4.	<b>Credits</b>	3
5.	<b>Contact Hours (L:T:P)</b>	2 1 0
6.	<b>Prerequisites (if any)</b>	Fluid Mechanics
7.	<b>Course Basket</b>	Discipline Core

8. **Course Summary:** This course will provide knowledge about various aspects of hydrology irrigation engineering.

9. **Course Objectives:** The objectives of this course is to understand the basic principles of hydrology accompanied with detailed study of various components of hydrological cycle such as precipitation and its losses in the form of evapo transpiration and runoff. This course will also provide knowledge about principles of water management, various methods of irrigation as well as the types and design of irrigation channels

### 10. Course Outcomes:

On completion of this course, the students will be able to:

CO1. Describe and identify different components of hydrologic cycle.

CO2. Explain and estimate runoff in a catchment.

CO3. Predict and compute flood and flood routing using different methods.

CO4. Identify the importance of irrigation practices and water requirement of crops.

CO5. Understand and evaluate different methods of irrigation and canal distribution system.

### 11. Curriculum Content:

#### Unit 1

**Precipitation and Water Losses:** Introduction, hydrologic cycle. Definition of Precipitation, form and types of precipitation. Recording and non-recording type rain gauges. Mass curve .computation of missing rainfall by different methods. Types of losses, infiltration- definition and measurement, evaporation - definition, factor affecting evaporation, methods of measurement, methods of reducing evaporation, consumptive use

#### Unit 2

**Runoff and its estimation:** Introduction, catchment area, component of runoff factor affecting runoff, rainfall–runoff relationship. Runoff hydrograph: components separation of base flow by different methods,  $\phi$ -index and W-index, unit hydrograph theory, assumption, limitations and advantages, derivation of unit hydrograph from simple storm Hydrographs, S curve and its uses, *Introduction to different types of flooding (riverine flood, flash flood and urban flood).*

#### Unit 3

**Flood and Flood Routing:** Introduction, Various methods of flood discharge-Rational method, Empirical method, Unit hydrograph method, Gumbel's method, Introduction to flood routing, Basic equations, Hydrologic storage routing, Attenuation, Hydrologic channel routing- Muskingum equation, Flood control, *Flood inundation mapping using ES techniques.*

# **Course Structure & Syllabus of B.Tech.– Civil Engineering**

## **Applicable for Batch: 2020-24**

### **Unit 4**

**Principles of water management:** Introduction, definition, soil classification, soil water relationship, Basic concept of groundwater, different types of geological formations of groundwater, specific yield and retention of aquifers, flow of water in saturated and unsaturated soils. Frequency of irrigation. Water requirement of crop. Duty, delta and Base period. Quality of water for irrigation. Irrigation efficiencies.

### **Unit 5**

**Methods of irrigation and irrigation channels:** Surface and subsurface irrigation, Classification of irrigation channels, component of canal system. Design of channels on alluvial soils Kennedy and Lacey theory. Design of Lined channels

### **Textbook(s):**

1. Modi., P. N., “Irrigation water resources and water power engineering”, Standard Book, House, New Delhi.
2. Garg, S. K., “Irrigation engineering and hydraulic structures”, Khanna Publishers, New Delhi, 23<sup>rd</sup> Edition, 2009.
3. Subramanya, K., “Engineering Hydrology”, Tata McGraw Hill, New Delhi, 4th Edition, 2013.

### **Reference Books:**

1. Sharma, R. K. Sharma, T. “A Text book of Hydrology and Water Resources Engineering”, Dhanpat Rai, New Delhi, 1987.
2. Sahasra Budhe, “Irrigation Engineering and Hydraulic Structures”, Dhanpat Rai Publication Ltd., New Delhi.

## **12. Teaching and Learning Strategy**

All materials (ppts, assignments, labs, etc.) will be uploaded in Moodle. Refer to your course in Moodle for details.

# Course Structure & Syllabus of B.Tech.– Civil Engineering

## Applicable for Batch: 2020-24

1.	Department offering the course	Civil Engineering
2.	Course Code	CEF208
3.	Course Title	Transportation Engineering - I
4.	Credits	4
5.	Contact Hours (L:T:P)	2 1 2
6.	Prerequisites (if any)	Strength of Material
7.	Course Basket	Discipline Core

8. **Course Summary:** Transportation -I course syllabus covers all essentials of Road Plans, Vehicle Characteristics, Highway Planning, Highway alignment, Highway Geometric Design, Highway Materials and their properties, Introduction to PMMS and Basics of Traffic Engineering, **Introduction to Traffic Engineering, Design of Pavements is as per latest IRC Codal Guidelines for Rigid and Flexible Pavements.**

### 9. Course Objectives:

This course provides in-depth exposure to highway development and planning, construction materials and their testing, highway geometric design, types of highway, highway design and their construction methods along with guidelines for their maintenance **traffic engineering.**

### 10. Course Outcomes:

On completion of this course, the students will be able to

CO1. Distinguish between Road Types and Different Modes.

CO2. Design Geometric Components of Highways.

CO3. Identify Traffic Management Solutions required for a given scenario.

CO4. Compare different Properties and materials required for road construction.

CO5. Design the composition of Flexible and Rigid Pavements.

### 11. Curriculum Content

#### Unit-1

**Highway Planning:** Importance of transportation, Different modes of transportation and their characteristics, Classification of roads, Different road patterns, Jaykar committee recommendations and implementation, Twenty year road development plans in India, IRC Vision- 2021 and Rural Road Vision- 225, Comparison and significance Calculation of Road Length as per the Road Development Plans. Introduction to recent developments in road network in India, Highway planning and alignment,

#### Unit-2:

**Highway Planning:** Importance of transportation, Different modes of transportation and their characteristics, Classification of roads, Different road patterns, Jaykar committee recommendations and implementation, Twenty year road development plans in India, IRC Vision- 2021 and Rural Road Vision- 225, Comparison and significance Calculation of Road Length as per the Road Development Plans. Introduction to recent developments in road network in India, Highway planning and alignment. *Application of RS, DEM and GIS in road design and planning, Introduction of methods of monitoring of road subsidence and slope stability.*

# **Course Structure & Syllabus of B.Tech.– Civil Engineering**

## **Applicable for Batch: 2020-24**

### **Unit-3:**

**Geometric Design:** Highway Cross sectional elements, Sight distances, Super elevation, Camber, Extra widening on curves, Design of horizontal and vertical alignments.

### **Unit-4**

**Traffic Engineering:** Introduction to Traffic Engineering, Traffic Characteristics, Road user and vehicular characteristics, Traffic Studies, Traffic operations, Traffic control devices.

### **Unit-5**

**Design of Pavements:** Various factors of pavement design, Concept of ESWL. IRC method of design of flexible pavements (as per IRC 37:2018). Design of Rigid Pavements: Design factors, load and temperature stresses, load transfer devices, design of Dowel bar and Tie bar, Type of Joints, IRC methods of design of SFRC pavements as per IRC:58-2015.

### **Text Books**

1. Khanna, S. K., Justo, C. E. J., Veeraraghavan, A., „Highway Engineering”, Nem Chand and Bros., Roorkee, 9th Edition, 2011.
2. Kadiyali, L. R., Lal, N. B., „Principles and Practices of Highway Engineering”, Khanna Publishers, New Delhi, 4th Edition, 2005.
3. Kadiyali, L. R., “Traffic Engineering and Transportation Planning”, Khanna Publishers, New Delhi, 6th Edition, 1997.
4. IRC-37-2018, “Guidelines for the Design of Flexible Pavements” (Fourth Revision), India Roads Congress, New Delhi, 2018.
5. IRC-58-2015,” Guidelines for the Design of Rigid Pavements” (Fourth Revision), India Roads Congress, New Delhi, 2015.

### **Reference Books**

1. Sharma, S. K., Sharma, R. C., “Principles and Design of Highway Engineering”, S. Chand & Company. 2012
2. Khanna, S. K., Justo, C. E. J., “Highway Material Testing Laboratory Manual”, Nem Chand And Bros., Roorkee.

### **List of Experiments**

- 1 Specific gravity test of bitumen
- 2 Ductility test of bitumen
- 3 Flash point and fire point test of bitumen
- 4 Penetration test of bitumen
- 5 Softening test of bitumen
- 6 Viscosity test of bitumen
- 7 Bitumen Content
- 8 Stripping Test on aggregate
- 9 Abrasion test of aggregate
- 10 Shape test (flakiness, elongation and angularity number) of aggregate



# **Course Structure & Syllabus of B.Tech.– Civil Engineering**

## **Applicable for Batch: 2020-24**

- 11 Impact value test of aggregate
- 12 Specific gravity test of aggregate
- 13 Crushing strength of aggregate
- 14 Marshall Test for stability and flow value
- 15 Benkelman Beam Test (Demonstration)

### **12. Teaching and Learning Strategy**

All materials (ppts, assignments, labs, etc.) will be uploaded in Moodle. Refer to your course in Moodle for details.

# Course Structure & Syllabus of B.Tech.– Civil Engineering

## Applicable for Batch: 2020-24

1.	<b>Department offering the course</b>	Civil Engineering
2.	<b>Course Code</b>	CEF301
3.	<b>Course Title</b>	Soil Mechanics
4.	<b>Credits</b>	4
5.	<b>Contact Hours (L:T:P)</b>	2 1 2
6.	<b>Prerequisites (if any)</b>	Strength of Material
7.	<b>Course Basket</b>	Discipline Core

**8. Course Summary:** To understand the basics of soils through hands on experience in the soil laboratory. Some of the important topics which will be learned during the course: soil structure and grain size; identification and classification of soils for engineering purposes; physical and engineering properties of soils; fundamental behavior of soils subjected to various forces; groundwater and seepage through soils; compaction; consolidation; shear strength. Upon successful completion of the course, students should be able to apply fundamentals of soil mechanics and principles of geotechnical engineering in the analysis, design, and construction of civil engineering projects.

**9. Course Objectives:** The objectives of this course are to understand the basic properties of soil, to determine the strength of soil so that various properties can be known before design and to undertake a variety of laboratory tests on soils.

### 10. Course Outcomes:

On completion of this course, the students will be able to

1. Develop and understand the physical relationships between physical characteristics and mechanical properties of soil.
2. Understand and experience experimental measurement of physical and mechanical soil properties commonly used in engineering practice.
3. Learn compaction and consolidation of soil
4. Learn analysis and measurement of shear strength of soil

### 11. Curriculum Content

#### Unit 1

**Introduction:** Different types of soil, Definition of void ratio, porosity, percentage air voids, air content, degree of saturation, moisture content, specific gravity, bulk density, dry density, saturated density, submerged density and their inter relationships.

**Index property of soil:** Definition and laboratory method of determination of index properties of soil: moisture content, specific gravity, particle size distribution (Sieve analysis and hydrometer analysis only), in situ density by Core cutter & sand replacement methods, relative density, consistency limits and indices and its determination, activity, thixotropy, sensitivity, collapsibility.

#### Unit 2

**Classification of soils:** Purpose of soil classification, basis of soil classification, particle size classification- textural soil classification and IS classification system, plasticity chart.

**Clay mineralogy and Soil Structure:** single grained, honey combed, flocculent and dispersed structure, Electric diffuse a double layer, Adsorb water, Structural water, capillary water, gravity water. Common Clay mineral in soil and their structure- Kaolinites, Illite and montmorillonite. Bulking of sand.

**Stress Distribution in soil:** Boussineq's Theory, Westergaurd's Theory, Isobars, Vertical pressure due to various loading conditions(line load, point load, uniform load, corner of uniformly loaded rectangular area, equivalent point load, trapezoidal method) Newmark's influence chart method.

# **Course Structure & Syllabus of B.Tech.– Civil Engineering**

## **Applicable for Batch: 2020-24**

### **Unit 3**

**Effective stress and permeability:** Effective stress, total pressure and pore water pressure, capillary phenomenon. Darcy's law- assumptions and validity, coefficient of permeability and its determination (laboratory, field and indirect method equations: Kozeny-Karman, Allen-Hazen, Terzaghi, Consolidation) factor affecting permeability, permeability of stratified soil.

**Seepage Analysis:** Pressure head, total head, elevation head, seepage pressure, critical hydraulic gradient, quick sand phenomenon, flow net, application of flow net, phreatic line and its determination.

### **Unit 4**

**Compaction of Soils:** Principle of compaction, standard and modified proctor's tests, Optimum moisture content, factor affecting compaction, proctor needle, effect of compaction on soil properties, method of compaction, compaction equipment's.

**Consolidation of Soils:** Definition, Initial compression, primary consolidation, secondary consolidation, normally consolidated, under consolidated and over consolidated soils, Terzaghi's one dimensional consolidation theory assumption and limitation, oedometer, Consolidation characteristics of soil, determination of consolidation characteristic, degree of consolidation and its determination, Time factor, determination of coefficient of consolidation by square root of time fitting method, logarithmic time fitting method. Settlement Analysis (total settlement, differential settlement, angular settlement). Immediate settlement. Determination of primary consolidation settlement and secondary consolidation.

### **Unit 5**

**Shear Strength of Soils:** Concept of shear strength, Mohr-coulomb theory, conventional and modified failure envelope, types of shear strength (undrained, drained shear strength), different types of shear test on the basis of drainage(UU, CU, CD). Laboratory test(direct shear, triaxial, vane shear, ring shear, unconfined compression test). Determination of sensitivity of clay. Shear characteristics of soil. Stress path.

### **List of Experiments**

1. Determination of Water content by Oven Dry Method.
2. Determination of Specific Gravity and Water content by Pycnometer Method.
3. Determination of In Situ Density and dry density by Core Cutter Method and Sand Replacement Method.
4. Determination of Particle Distribution curve by Sieve Analysis.
5. Determination of Specific Gravity by Hydrometer Analysis.
6. Determination of Liquid Limit, Plastic Limit & Shrinkage Limit.
7. Determination of coefficient of permeability by Permeability Test (Constant and Variable).
8. Determination of Optimum moisture content by Proctor Compaction Test
9. Determination of shear strength by Triaxial Compression Test
10. Determination of shear strength by Direct Shear Test.

### **Text books:**

1. Punmia, B. C., Jain, A. K., Jain, A. K., "Soil Mechanics and Foundations", Laxmi publication Co. New Delhi, 16<sup>th</sup> edition, 2005.
2. Ranjan, G., Rao, A. S. R., "Basic and Applied Soil Mechanics", New Age International (P) Ltd., New Delhi, 2<sup>nd</sup> Edition, 2005.

### **References books:**

1. Das, B. M., Sobhan, K., "Principles of Geotechnical Engineering" 8<sup>th</sup> Edition. Thomson business information India (P) Ltd., India
2. Singh, A., Chowdhary, R., "Soil Engineering in Theory and Practice", CBS publishers

# **Course Structure & Syllabus of B.Tech.– Civil Engineering**

## **Applicable for Batch: 2020-24**

- and distributors Ltd., New Delhi.
3. Murthy, V. N. S., “Soil Mechanics and Foundation engineering”, 4<sup>th</sup> Edition, UBS publishers and Distributors, New Delhi.
  4. Sitaram, T. G., Ramamuthy, T. N., “Geotechnical engineering”, S. Chand & Co New Delhi. Off., H. M. S., “Soil mechanics for road engineers, Road Research Laboratory”, U. K., Vol. I, 1952

### **12. Teaching and Learning Strategy**

All materials (ppts, assignments, labs, etc.) will be uploaded in Moodle. Refer to your course in Moodle for details.

# Course Structure & Syllabus of B.Tech.– Civil Engineering

## Applicable for Batch: 2020-24

1.	<b>Department offering the course</b>	Civil Engineering
2.	<b>Course Code</b>	CEF354
3.	<b>Course Title</b>	Transportation Engineering - II
4.	<b>Credits (L:T:P:C)</b>	4
5.	<b>Contact Hours (L:T:P)</b>	3 1 0
6.	<b>Prerequisites (if any)</b>	Transportation Engineering I
7.	<b>Course Basket</b>	Discipline Core

8. **Course Summary:** Transportation – II covers the basic characteristics of Rail and Air Transport, components of Railway transportation and the Airport Engineering along with the design of their geometric components.

### 9. Course Objective:

This course covers complete knowledge of “Cross-section, Components, and geometric design of railway track as well as development of railway station and yards.” In this course all Airport characteristics, Geometric design and Air traffic control are covered.

### 10. Course Outcomes:

On completion of this course, the students will be able to

1. Working of world’s largest rail network,
2. Designing of rail tracks.
3. Managing safety issues in railways.
4. Airport runway designing.
5. Air traffic control in the busiest route.

### 11. Curriculum Content:

#### Unit 1

**Introduction and Components:** Role of railways in transportation, The Permanent way, Gauges in railway track, Typical cross sections of railway track, Coning of wheels, Track components: Type of rails, Rail Joints and Welding of rails, Sleepers, Ballast, and Fixtures, Creep of Rails, Adzing of sleepers Stresses in rails, Tractive resistances.

#### Unit 2

**Geometric Design of Railway Tracks:** Geometric design of tracks- speed calculations, Gradients-ruling, momentum, pusher and minimum gradient, Super elevation, Cant Deficiency, Negative super elevation, Component of turn outs, points and crossings, Track Junctions, cheek rails on curves

#### Unit 3

**Railway Station and Yards:** Classification of railway Stations, Types of station Yards, Signalling and Control System, Interlocking of Signals and Points. Modern Development of Railways Earthwork – Stabilization of track on poor soil – Tunneling Methods, drainage and ventilation – Calculation of Materials required for track laying - Construction and maintenance of tracks – Modern methods of construction & maintenance - passenger amenities- Urban rail – Infrastructure for Metro, Mono and underground railways. Objectives, Classification of Signals, Types of Signals in Stations and Yards, Automatic Signalling, Principal of Interlocking MAGLEV, TACV

#### Unit 4

Role of Airways in transportation, Aeroplane Component Parts, Aircraft Characteristics, Airport planning, Site selection, Airport Obstructions, Air transport characteristics-airport classification-airport planning: objectives, components, layout characteristics, socio-economic characteristics of the Catchment area, criteria for airport site selection and ICAO stipulations, Typical airport layouts, Case studies, Parking and circulation area.

# **Course Structure & Syllabus of B.Tech.– Civil Engineering**

## **Applicable for Batch: 2020-24**

### **Unit 5**

**Geometric Design and Air Traffic Control:** Wind rose diagram, Basic runway length, and corrected runway length, Geometric runway and Taxiway Design , Turning radius of taxiway, Exit taxiway-design factors and elements, Airport markings and lightings, Air traffic control, Instrument landing systems. Configuration and Pavement Design Principles – Elements of Taxiway Design – Airport Zones – Passenger Facilities and Services – Runway and Taxiway Markings and lighting.

### **Text Books**

1. Saxena, S. C., Arora, S. P., “A Text Book of Railway Engineering”, DhanpatRai Publications Pvt. Ltd.,NewDelhi,6thEdition,2001.
2. Khanna, S. K., Arora, M. G., and Jain, S. S., “Airport Planning and Design”, Nem Chand and Bros.,Roorkee,6thEdition,2008.

### **Reference Books**

1. Horonjeff, R. M., Mckelvey, F. X., Sproule, W. J., and Young, S., “Planning and Design of Airports”, Mc-Graw Hill Publications, New Delhi, 5th Edition, 2010.
2. Chandra, S., and Agrawal, M. M., “Railway Engineering”, Oxford University Press, 2007.
3. Saxena S.C, “Airport Engineering, Planning and Design”, CBS Publishers and Distributors , Pvt. Ltd. Reprint Ed. 2015.

### **12. Teaching and Learning Strategy**

All materials (ppts, assignments, labs, etc.) will be uploaded in Moodle. Refer to your course in Moodle for details.

# Course Structure & Syllabus of B.Tech.– Civil Engineering

## Applicable for Batch: 2020-24

1.	<b>Department offering the course</b>	Civil Engineering
2.	<b>Course Code</b>	CEF302
3.	<b>Course Title</b>	Design of Reinforced Concrete Structures
4.	<b>Credits</b>	4
5.	<b>Contact Hours (L:T:P)</b>	3 1 0
6.	<b>Prerequisites (if any)</b>	Strength of Materials, Concrete Technology.
7.	<b>Course Basket</b>	Discipline Core

8. **Course Summary:** Course will make the students able to understand various design parameters, analysis and design methodology of RCC structures

9. **Course Objectives:** The course is designed to make students aware about the various principles of reinforced concrete structures and to design various elements using limit state method.

### 10. Course Outcomes:

On completion of this course, the students will be able to

1. Understand the principle of RC Structure
2. Understand the design of structure with limit state analysis.
3. Identify different elements of a R.C.C structure as per IS code provisions
4. Understand the reinforcement detailing of various building components.

### 11. Curriculum Content

#### Unit 1

**Introduction to Limit State Design:** Introduction about the materials used in the concrete. Various design approaches and introduction to working stress method. Design of flexural members using working stress method. Philosophy and principle of limit state design along with the assumptions, concept of balanced, under reinforced and over reinforced sections, limit state of collapse in flexure of rectangle and flanged sections with examples.

#### Unit 2

**Limit state design of beams:** Design problems on singly doubly and fanged simply supported beams with torsion shear and anchorage consideration. Design of cantilever beams and continuous beams

#### Unit 3

**Limit State Design of Slabs:** Introduction to one way and two way slabs, design of one way cantilever, simply supported and continuous slab and design of two way slabs by IS code method.

#### Unit 4

**Limit State Design of Columns and Footings:** General design concept of compression members, Design of short axially loaded columns, Design of columns subjected to uniaxial and biaxial bending using interaction curves, Design Principles of slender columns, Design and detailing of isolated rectangular and basic principles of trapezoidal footing for axial load and uniaxial moment.

#### Unit 5

**Design of Stair Cases:** General specifications, Types of stair cases, Loads on stair cases, Effective span of stairs, Design of dog legged stair case, Design principles of other type of staircases.

### Text Books

# **Course Structure & Syllabus of B.Tech.– Civil Engineering**

## **Applicable for Batch: 2020-24**

1. Reinforced concrete design by N. Krishna Raju and R.N. Pranesh, New age International Publishers, New Delhi
2. Pillai, S. U., Menon, D., “Design of reinforced concrete structures”- Tata McGraw hill publications, 3rd Edition, 2009.
3. Varghese, P. C., “Limit State Design of Reinforced Concrete”, PHI Learning Pvt. Ltd., India, 2nd Edition, 2008

### **References**

1. Design of concrete structures – Arthus H. Nilson, David Darwin, and Chorles W. Dolar, Tata McGraw-Hill, 3rd Edition, 2005
2. Sinha, S. N., “Reinforced concrete Design”, Tata McGraw-Hill Education, New Delhi, 2002 .
3. Park, R., Paulay, T., “Reinforced Concrete Structures”, John Wiley and Sons, New York, 1975.
4. Jain, A. K., “Reinforced Concrete Limit State Design”, Nemchand& Brothers, Roorkee

### **12. Teaching and Learning Strategy**

All materials (ppts, assignments, labs, etc.) will be uploaded in Moodle. Refer to your course in Moodle for details.



# Course Structure & Syllabus of B.Tech.– Civil Engineering

## Applicable for Batch: 2020-24

1.	<b>Department offering the course</b>	Civil Engineering
2.	<b>Course Code</b>	CEF355
3.	<b>Course Title</b>	Building Science
4.	<b>Credits</b>	3
5.	<b>Contact Hours (L:T:P)</b>	2 0 2
6.	<b>Prerequisites (if any)</b>	None
7.	<b>Course Basket</b>	Elective

8. **Course Summary:** Course will enhance knowledge on basic fundamentals of building planning, design and construction materials

9. **Course Objectives:** Students are expected to be more conversant with minute details of civil engineering domain structures such as residential houses, storage ware-houses and industrial buildings.

### 10. Course Outcomes:

On completion of this course, the students will be able to

1. Able to decide on the selection of types of materials used for building construction
2. Able to decide on the selection of types of doors, windows and stairs.
3. Select suitable type of flooring, plastering and also suitable colour to the building.
4. Select and design suitable type of framework using various non-structural connections

### 11. Curriculum Content:

#### Unit 1

**Introduction to Building Planning:** Planning of Residential Buildings, Site Selection criteria. Principles of Building planning. Significance Sun diagram. Wind Diagram. Orientation, factors affecting, criteria under Indian condition. Low cost Housing-Materials & Methods (conceptual introduction only) Maintenance, Repairs, Rehabilitation of Structures (conceptual introduction only).

#### Unit 2

**Building Services:** Plumbing system, Various Materials for system like PVC, GI, AC, CI, HDPE, and Stoneware. Various types of traps, Fittings, Chambers, Need of Septic Tank, Concept of Plumbing & Drainage plan, introduction to rainwater harvesting. Concept of rain water Gutters. Rainwater outlet & Down Tank Systems.

#### Unit 3

**Electrification:** Concealed & Open Wiring, Requirements & Location of various points, Concept of earthing. Fire resistance in building: Fire protection precautions, confining of fire, fire hazards, Characteristics of fire resisting materials. **Ventilation:** - Definition and necessity of Ventilation, functional requirement, various system & section criteria. Air conditioning: - Purpose, Classification, Principles, Systems & Various Components of the same.

#### Unit 4

**Thermal Insulation:** - General concept, Principles, Materials, Methods, Computation of Heat loss & heat gain in Buildings. **Introduction to Acoustics:** Absorption of sound, various materials, Sabine's formula, optimum reverberation time, conditions for good acoustics. **Sound Insulation:** Acceptable noise levels, Noise prevention at its source, Transmission of noise. Noise control - general considerations.

### UNIT 5

# **Course Structure & Syllabus of B.Tech.– Civil Engineering**

## **Applicable for Batch: 2020-24**

**Building Finishes: Paints:** Different types and application methods. Varnishes & application methods. Plastering, Pointing & various techniques. Tile cladding, skirting, dado work with various materials. Miscellaneous finishes such as POP, sand blasting techniques, wall paper.

### **List of Experiments**

1. Introducing AutoCAD using various Commands
2. AUTOCAD 2D drawing; plan, elevation, section etc using all the 2D commands according to building planning bye laws under regulations as per SP-7, 1983 National Building code of India
3. Drawing to a scale in AUTOCAD: Foundations, Stone Masonry, Brick masonry bonds, Doors & Windows, Stairs
4. Sketch Book :
  - A. Lettering, Symbols, Types of lines and dimensioning as per IS 962.
  - B. Types of Stone masonry
  - C. Types of Doors
  - D. Types of Windows
  - E. Types of Roofs
  - F. Types of Stairs
  - G. R.C.C. Lintel & Chajja
  - H. Types of Timber Trusses
5. Flexure test on flooring tiles.
6. Water absorption & compression test on Burnt brick.

**\*NOTE: Use of SolidWorks or any other numerical tool can also be used for all of the above drawing practical**

### **Textbook(s):**

1. Kumar, S., “Building Construction”, Standard Publishers Distributors, New Delhi, 16<sup>th</sup> Edition, 2006.
2. Rangwala, S. C., “Engineering Materials (Material Science)”, Charotar Publishing House Pvt. Limited, 2008.

### **Reference Books:**

1. David Frey, “AutoCAD”, BPB Sybex Publications
2. George Omura, “ AutoCAD”
3. I.S. 962 – 1989 Code for Practice for Architectural and Building Drawings
4. Shah, Kale, Patki, “ Building Drawing”, Tata McGraw- Hill
5. SP 7- National Building Code Group 1 to 5 - B.I.S. New Delhi
6. Y. S. Sane, “ Building Design and Drawing”, Allied Book Stall, Pune
7. Rai, M., Jaisingh, M. P., “Advanced Building Materials and Construction” CBRI Publications, Roorkee, 1985.

### **12. Teaching and Learning Strategy**

All materials (ppts, assignments, labs, etc.) will be uploaded in Moodle. Refer to your course in Moodle for details.

# Course Structure & Syllabus of B.Tech.– Civil Engineering

## Applicable for Batch: 2020-24

1.	<b>Department offering the course</b>	Civil Engineering
2.	<b>Course Code</b>	CEFXXX
3.	<b>Course Title</b>	Technical Training I
4.	<b>Credits</b>	2
5.	<b>Contact Hours (L:T:P)</b>	0 0 4
6.	<b>Prerequisites (if any)</b>	Building Design, Construction & Drawing
7.	<b>Course Basket</b>	Skill Enhancement Course

8. **Course Summary:** Course includes drawing details of connections, features and specification

9. **Course Objectives:** Understanding the various drawing details and their implications

### 10. Course Outcomes:

On completion of this course, the students will be able to

1. Draw various specifications in residential buildings
2. Draw and understand the various bye laws corresponding to industrial and residential buildings.

### 11. Curriculum Content:

#### List of Experiments

1. Planning and drawing of (G+2) residential building in a computer based drawing tool (e.g. AutoCAD)
  - a. Plan and elevation
  - b. Section passing through staircase
  - c. Site plan. Area statement & brief specifications.
2. Full set of working drawings of (G+2) residential building in a computer based drawing tool (e.g. AutoCAD)
  - a. Different types of foundation: combined, isolated
  - b. Furniture layout plan.
  - c. Electrification plan
  - d. Water supply & drainage plan.
3. Project report in the form of drawings giving details of following systems in a computer based drawing tool (e.g. AutoCAD)
  - a. Drainage System
  - b. Water Supply System
  - c. Water Tank
  - d. H Septic Tank
  - e. Design of terrace Drainage System

#### Textbook(s):

3. Kumar, S., “Building Construction”, Standard Publishers Distributors, New Delhi, 16<sup>th</sup> Edition, 2006.
4. Rangwala, S. C., “Engineering Materials (Material Science)”, Charotar Publishing House Pvt. Limited, 2008.

#### Reference Books:

1. I.S. 962 – 1989 Code for Practice for Architectural and Building Drawings
2. Shah, Kale, Patki, “ Building Drawing”, Tata McGraw- Hill
3. SP 7- National Building Code Group 1 to 5 - B.I.S. New Delhi

# **Course Structure & Syllabus of B.Tech.– Civil Engineering**

## **Applicable for Batch: 2020-24**

4. Y. S. Sane, “ Building Design and Drawing”, Allied Book Stall, Pune

### **12. Teaching and Learning Strategy**

All materials (ppts, assignments, labs, etc.) will be uploaded in Moodle. Refer to your course in Moodle for details.

# Course Structure & Syllabus of B.Tech.– Civil Engineering

## Applicable for Batch: 2020-24

1.	<b>Department offering the course</b>	Civil Engineering
2.	<b>Course Code</b>	CEF303
3.	<b>Course Title</b>	Design of Steel Structure
4.	<b>Credits (L:T:P:C)</b>	4
5.	<b>Contact Hours (L:T:P)</b>	3 1 0
6.	<b>Prerequisites (if any)</b>	Strength of Materials
7.	<b>Course Basket</b>	Discipline Core

**8. Course Summary:** This course consists of plastic analysis of the structure, various rolled sections which are used in the construction industry for the steel buildings along with their properties. Bolted and welded connections. Different tension, compression members and their design. Analysis and design of flexural members and intro to the plate girders used in the steel structures.

**9. Course Objectives:** The course objective is to gain the knowledge regarding design of steel structures, stability, strength and serviceability.

### 10. Course Outcomes:

On completion of this course, the students will be able to

1. Design of Structural members with different types of connections.
2. Design of Compression members.
3. Design of Beams.
4. Understand flexural behavior of steel components

### 11. Curriculum Content

#### Unit 1

**Introduction & Plastic Analysis:** Introduction, Types & properties of structural steel rolled sections, Grades of steel, Codal Provisions Plastic behaviour of structural steel – shape factor – plastic hinge concept – collapse load – methods of plastic analysis – plastic design of beams and portal frames.

#### Unit 2

**Connections:** Concept in the design of connections, Codal Provisions, Simple and moment resistant welded and bolted connections and eccentric connections

#### Unit 3

**Tension Members:** Introduction, Codal provisions, Analysis and design of tension members with different cross sections subjected to axial tension, splicing of tension member and Lug angle

#### Unit 4

**Compression Members:** Codal provisions, Slenderness ratio, Analysis and design of simple compression members (angles and I-Sections), including continuous strut and discontinuous strut. Built up compression members, Lacing and battening.

#### Unit-5

**Flexural Members:** Concept in the design of flexural member, Codal provisions, Analysis and design of laterally restrained and unrestrained beams, built up beams, Web buckling and web crippling. Introduction to lintels, purlins and castellated beams. Introduction to plate girders.

#### Textbook(s):

1. Design of Steel structures by K.S. Sai Ram, Person Education.
2. Design of Steel Structures Vol. 1 & 2 – Ramchandra, Standard Publications.
3. Design of steel structures, Structures, S.S. Bhavikatti, I.K Publication House, New Delhi, 2010.
4. Structural Design and Drawing by N.Krishna Raju, Universities

# **Course Structure & Syllabus of B.Tech.– Civil Engineering**

## **Applicable for Batch: 2020-24**

### **Reference Books:**

1. Limit State Design Steel Structures, S .k. Duggal, Tata Mc Grawhill.
2. Design of Steel Structures - N. Subramanian, Oxford University Press
3. IS800:2007, Code of practice for general construction in steel.

### **12. Teaching and Learning Strategy**

All materials (ppts, assignments, labs, etc.) will be uploaded in Moodle. Refer to your course in Moodle for details.

# Course Structure & Syllabus of B.Tech.– Civil Engineering

## Applicable for Batch: 2020-24

1.	<b>Department offering the course</b>	Civil Engineering
2.	<b>Course Code</b>	CEF356
3.	<b>Course Title</b>	Foundation Engineering
4.	<b>Credits (L:T:P:C)</b>	4
5.	<b>Contact Hours (L:T:P)</b>	3 1 0
6.	<b>Prerequisites (if any)</b>	Soil Mechanics
7.	<b>Course Basket</b>	Discipline Core

8. **Course Summary:** The course will focus on the design of shallow foundation and axially loaded pile and well foundation. Students will learn about the stability of soil under different conditions. Upon successful completion of the course, students should be able to apply fundamentals of soil mechanics and principles of geotechnical engineering in the analysis, design, and construction of civil engineering projects.

### 9. Course Objectives:

The objective of this course is to learn application of soil mechanics and other related techniques to design and analyse various types of foundation by learning methods of soil exploration; bearing capacity and settlements determination for shallow and deep foundation and provision of earth retaining structures.

### 10. Course Outcomes:

On completion of this course, the students will be able to

1. Learn about types and purposes of different foundation systems and structures.
2. Learn about the systematic methods for designing foundations.
3. Evaluate the feasibility of foundation solutions to different types of soil conditions
4. Learn about applications of geotextiles for reinforced earth and soil stabilization.

### 11. Curriculum Content

#### Unit-1

**Earth Pressures and Slope Stability:** Brief review of soil mechanics principles used in foundation engineering, Earth pressure at rest, Active and passive earth pressure, Rankine's and Coulomb's earth pressure theories, Earth pressure due to surcharge, Retaining walls, Stability analysis of retaining walls, Slopes: Mode of failure- Mechanism, Stability analysis of infinite slopes, Swedish slip circle method, Taylor's stability number.

#### Unit-2

**Shallow Foundations:** Types of Foundations, Mechanism of load transfer in shallow and deep foundations, Shallow foundations, Terzaghi's bearing capacity theory, Computation of bearing capacity in soil, Effect of various factors, Use of field test data in design of shallow foundations, Stress below the foundations, Settlement of footings and rafts, proportioning of footings and rafts, Sheet piling and bracing of foundation excavation.

#### Unit-3

**Deep Foundations:** Types and methods of construction, estimation of pile capacity, Capacity and settlement of group of piles, Group efficiency, Proportioning of piles, Under rammed piles. Standard penetration test.

#### Unit- 4

**Well foundation:** Methods of construction of well foundation, Tilt and Shift, Remedial measures, Bearing capacity, Settlement and lateral stability of well foundation.

#### Unit 5

# **Course Structure & Syllabus of B.Tech.– Civil Engineering**

## **Applicable for Batch: 2020-24**

**Soil Exploration, Reinforced Earth and Geotextiles:** Reinforced Earth, Geotextile: Definition, types, functions. Use of Geotextiles in Earth dams, roads, railways, erosion control and bearing capacity improvement. Storage, handling and placement of Geotextiles. Methods of soil exploration, Boring, Sampling, Penetration tests, Correlations between penetration resistance and soil design parameters, geophysical and advance soil exploration methods.

### **Text Books**

1. Punmia, B. C., Jain, A. K., Jain, A. K., “Soil Mechanics and Foundations”, Laxmi publication Co. New Delhi, 17th edition, 2017.
2. Ranjan, G., Rao, A. S. R., “Basic and Applied Soil Mechanics”, New Age International (P) Ltd., New Delhi, 3rd Edition, 2016.

### **References**

1. Bowles, J. E., “Foundation Analysis and Design”, McGraw-Hill, New Delhi, International Edition, 2001.
2. Singh, A., Chowdhary, G. R., “Soil engineering in theory and practice”, CBS Publishers, New Delhi.

### **12. Teaching and Learning Strategy**

All materials (ppts, assignments, labs, etc.) will be uploaded in Moodle. Refer to your course in Moodle for details.



# Course Structure & Syllabus of B.Tech.– Civil Engineering

## Applicable for Batch: 2020-24

1.	<b>Department offering the course</b>	Civil Engineering
2.	<b>Course Code</b>	CEF304
3.	<b>Course Title</b>	Structural Analysis II
4.	<b>Credits (L:T:P:C)</b>	4
5.	<b>Contact Hours (L:T:P)</b>	3 1 0
6.	<b>Prerequisites (if any)</b>	Strength of Materials and Structural Analysis I
7.	<b>Course Basket</b>	Discipline Core

8. **Course Summary:** This course consists of various methods of finding the shear force, bending moment, slope and deflection of the various elements of the indeterminate structures.

9. **Course Objectives:** The course is designed to make students aware about the basics and analysis of indeterminate structures and different design principles used there in.

### 10. Course Outcomes:

On completion of this course, the students will be able to

1. Analyze the Indeterminate beam structures.
2. Analyze the Indeterminate framed structures.
3. Analyze the beams and frames by matrix method.
4. Analyze the various components of Indeterminate Structures

### 11. Curriculum Content

#### Unit 1

**Slope-Deflection Method:** Three moment equation, Introduction and Derivation of slope-deflection equation, application to continuous beams with and without sinking of supports, Analysis of Single Bay – single storey Portal Frames Including Side Sway. Shear force and bending moment diagrams.

#### Unit 2

**Moment Distribution Method:** Analysis of continuous beams with and without sinking of supports using Moment Distribution Method, Analysis of Single Bay Single Storey Portal Frames including side sway. Analysis of inclined frames.

#### Unit 3

**Kani's Method:** Analysis of continuous beams including settlement of supports. Analysis of single bay single storey and single bay two Storey Frames by Kani's Method Including Side Sway. Shear force and bending moment diagrams

#### Unit 4

**Approximate Methods of Analysis:** Introduction – Analysis of multi-storey frames for lateral loads: Portal Method and Cantilever method. Analysis of multi-storey frames for gravity (vertical) loads. Two Hinged Arches- Introduction, Classification of Two hinged Arches, Analysis of two hinged parabolic arches

#### Unit 5

**Matrix Methods of Analysis:** Introduction to stiffness and flexibility method, Analysis of structural elements using stiffness method and flexibility method and draw Shear force and bending moment diagrams.

#### Text Books

1. Jain, A. K., “Elementary Structural Analysis”, Nem Chand Publishers, Roorkee, 1990.
2. Ramamrutham, S., Narayan, R., “Theory of Structure”, Dhanpat Rai & Co. Ltd.

# **Course Structure & Syllabus of B.Tech.– Civil Engineering**

## **Applicable for Batch: 2020-24**

### **References**

1. Norris, C. H., Wilbur, J. B., “Elementary Structural Analysis”, International Student Edition, Literary Licensing, LLC, 2012.
2. Reddy, C. S., “Basic Structural Analysis”, Tata McGraw Hill, New Delhi, 2011.

### **12. Teaching and Learning Strategy**

All materials (ppts, assignments, labs, etc.) will be uploaded in Moodle. Refer to your course in Moodle for details.

# Course Structure & Syllabus of B.Tech.– Civil Engineering

## Applicable for Batch: 2020-24

1.	<b>Department offering the course</b>	Civil Engineering
2.	<b>Course Code</b>	CEFXXX
3.	<b>Course Title</b>	Technical Training II
4.	<b>Credits</b>	2
5.	<b>Contact Hours (L:T:P)</b>	0 0 4
6.	<b>Prerequisites (if any)</b>	Technical Training I
7.	<b>Course Basket</b>	Skill Enhancement Course

8. **Course Summary:** Increasing the imagination and drawing abilities corresponding to technical aspects of the civil engineering domain

9. **Course Objectives:** Increasing abilities of converting the specification knowledge into drawings

### 10. Course Outcomes:

On completion of this course, the students will be able to

1. Apply knowledge of drawings in industrial and residential buildings
2. Understand connections in RCC as well as Timber and Metal

### 11. Curriculum Content:

#### List of Experiments

#### 1. Drawing of STEEL building components including

- 1.1. Industrial building including roof truss, purlin, bracings, gantry girder, column, column base and column to baseplate connections.
- 1.2. Welded plate girder, design of cross section, curtailment of flange plates, stiffeners and connections
- 1.3 Foot Bridge: Influence lines, cross beam, main Truss, Raker, joint details, support details.

#### 2. Drawing of REINFORCED CEMENT CONCRETE building components including

- 1.1 Primary and secondary beams
- 1.2 Column detailing
- 1.3 Column footing detailing
- 1.4 Slab detailing

#### Textbook(s):

1. Vaisakh, G., *Design of Steel Structures–Limit State Method*
2. Kazuhiro HIRAKIDA, *Design and Construction of Factory Architecture in the Dawn of Domestic Steel Structures*, NIPPON STEEL & SUMITOMO METAL TECHNICAL REPORT  
No. 115 JULY 2017

#### Reference Books:

1. I.S. 962 – 1989 Code for Practice for Architectural and Building Drawings
2. Shah, Kale, Patki, “ Building Drawing”, Tata McGraw- Hill
3. SP 7- National Building Code Group 1 to 5 - B.I.S. New Delhi
4. Y. S. Sane, “Building Design and Drawing”, Allied Book Stall, Pune

### 12. Teaching and Learning Strategy

All materials (ppts, assignments, labs, etc.) will be uploaded in Moodle. Refer to your course in Moodle for details.

# Course Structure & Syllabus of B.Tech.– Civil Engineering

## Applicable for Batch: 2020-24

1.	<b>Department offering the course</b>	Civil Engineering
2.	<b>Course Code</b>	CEFXXX
3.	<b>Course Title</b>	Value Added Training I
4.	<b>Credits</b>	2
5.	<b>Contact Hours (L:T:P)</b>	0 0 4
6.	<b>Prerequisites (if any)</b>	Design of Reinforced Concrete Structures
7.	<b>Course Basket</b>	Skill Enhancement Course

8. **Course Summary:** Learning commercial codes **STAAD PRO** and **E-Tabs**.  
Knowledge of this course will increase the proficiency and employability of the students

9. **Course Objectives:** Increasing abilities of converting the civil engineering knowledge to solving the practical problems using numerical solution in linear and nonlinear range.

### 10. Course Outcomes:

On completion of this course, the students will be able to

1. Learn commercial codes for different types of problems
2. Interpret the domain knowledge converting that into mathematical modelling and solving the multi-story building analysis problem.

### 11. Curriculum Content:

#### List of Experiments

1. **STAAD PRO for analysis of multi-storey building**
  - 1.1 Introductory commands using GUI
  - 1.2 Commands using editor file
  - 1.3 Defining Geometry
  - 1.4 Defining Load
  - 1.5 Defining design parameters and Load combinations
  - 1.6 Analyzing and designing
  - 1.7 Detailing of various components
2. **E-Tabs for analysis of multi-storey building**
  - 1.1 Introductory commands using GUI
  - 1.2 Commands using editor file
  - 1.3 Defining Geometry
  - 1.4 Defining Load
  - 1.5 Defining nonlinear material properties
  - 1.6 Defining design parameters and Load combinations
  - 1.7 Analyzing and checking the safety of cross sections of elements
  - 1.8 Detailing of various components

#### Textbook(s)

1. Manual : STAAD PRO
2. Manual : E-Tabs

### 12. Teaching and Learning Strategy

All materials (ppts, assignments, labs, etc.) will be uploaded in Moodle. Refer to your course in Moodle for details.

# Course Structure & Syllabus of B.Tech.– Civil Engineering

## Applicable for Batch: 2020-24

1.	<b>Department offering the course</b>	Civil Engineering
2.	<b>Course Code</b>	CEF401
3.	<b>Course Title</b>	Estimation and Costing
4.	<b>Credits</b>	4
5.	<b>Contact Hours (L:T:P)</b>	3 1 0
6.	<b>Prerequisites (if any)</b>	Design of Reinforced Concrete Structures
7.	<b>Course Basket</b>	Discipline Core

8. **Course Summary:** Evaluating the material quantity for different types of structures

9. **Course Objectives:** To learn the estimation of RCC, masonry and road structures and to study different terms related to contracts and tenders.

### 10. **Course Outcomes:**

On completion of this course, the students will be able to

1. Compare various sources of energy for power development and have knowledge about the distribution of hydropower potential in India.
2. Compute Firm Power by drawing Flow and Load duration Curves.
3. Have information about various types of hydropower plants and Power development schemes.
4. Design Water conductor system namely Penstock, Trash rack, Surge tanks etc
5. Apply knowledge in the field of Small Hydro power development.

### 11. **Curriculum Content:**

#### Unit 1

##### **Introduction & Estimation of Buildings**

**Introduction** - Importance of estimation in Civil Engineering, Different types of Estimates.

**Estimation methods:** Methods in Estimation, Methods of taking out quantities and cost by Centre line method and long wall and short wall method.

#### Unit 2

##### **Estimation of R.C.C. Structures**

**Estimation of simple RCC structures** - Estimates of components RCC works in beams, column footings and roof slabs; **Estimation of complex RCC structures** - Estimation of septic tank, manhole and RCC slab culverts.

#### Unit 3

##### **Specifications and Rate Analysis**

**Specifications of items:** Definition of specifications, objectives of writing specification, essentials of specification of various items of working in buildings; **Rate Analysis of quantities estimated:** Importance working out quantities and rates for the following standard items of works-earth works in different types of soils, cement concrete of different mixes, Brick masonry, Painting and steel works, wooden works for doors, windows.

#### Unit 4

##### **Estimation of Earth Work and Road Projects:**

**Earthwork:** Methods for computation of Earthwork-cross sections-mid sections formula, trapezoidal and average end area or mean sectional formula; **Road Projects:** Estimation of Road Works -WBM, Bituminous mixes and cement concrete roads.

#### Unit 5 Contracts and Tender

# **Course Structure & Syllabus of B.Tech.– Civil Engineering**

## **Applicable for Batch: 2020-24**

**Contracts:** Types of contract, essential of contracts agreement and document- legal aspects, penal provisions on breach of contract; **Tender:** Tender- E.M.D, Security deposit, Tender form, Tender notification procedures, Nominal muster roll, Measurement book.

### **Text Books**

1. Chakraborti, M., “Estimating, Costing, Specification and Valuation in Civil Engineering”, Published by author, Calcutta.
2. Dutta, B. N., “Estimating and Specification” UBS publishers and distributors, New Delhi, 2002.

### **References**

1. Basin, P. L., “Quality surveying”, S. Chand and Co., New Delhi.
2. Rangawala, S. C., “Estimating and Specification”, Charotar publishing House, Anand.  
Nanavati, J., “Professional Practice for Civil engineers”.

### **12. Teaching and Learning Strategy**

All materials (ppts, assignments, labs, etc.) will be uploaded in Moodle. Refer to your course in Moodle for details.

# Course Structure & Syllabus of B.Tech.– Civil Engineering

## Applicable for Batch: 2020-24

1.	<b>Department offering the course</b>	Civil Engineering
2.	<b>Course Code</b>	CEF447
3.	<b>Course Title</b>	Construction Planning and Project Management
4.	<b>Credits</b>	3
5.	<b>Contact Hours (L:T:P)</b>	2 1 0
6.	<b>Prerequisites (if any)</b>	Concrete Technology and Estimation And Costing
7.	<b>Course Basket</b>	Discipline Core

8. **Course Summary:** Course provides the tools to analyze the time and resources which subsequently provides cost for the project

9. **Course Objectives:** To learn network techniques in construction planning and management and to learn control and safety procedures in construction

### 10. Course Outcomes:

On completion of this course, the students will be able to

1. Identify the various network techniques for planning and scheduling any project
2. Learn the concepts involved in PERT network analysis techniques
3. Learn the concepts involved in CPM network analysis techniques
4. Understand the importance of safety in construction projects
5. Identify the various machines involved in construction projects.

### 11. Curriculum Content:

#### Unit 1

**Network Techniques:** Introduction to network techniques, Use of Computer aided CPM and PERT for planning, Scheduling and control of construction works, Bar charts, Error in networks, Types of nodes and node numbering systems

#### Unit 2

**PERT:** Time Estimates, probability distribution, time computations, slack, network analysis, critical path

#### Unit 3

**CPM:** CPM processes, network, activity time estimates, float, network analysis, critical path

#### Unit-4

**Control and Safety in Construction:** Construction quality control and inspection, Significance of variability and estimation of risk, Construction cost control, crashing of networks. Resource planning and scheduling, Introduction, Evolution of safety, Cause of accident, injury. Principle of safety, safety act and regulations, roles of safety personnel, safety management system

#### Unit- 5

**Construction Equipment and Methods:** Equipment for earthworks, Concrete construction, Aggregate production, Concrete production, Handling and placement, Mixers, Vibrators and temperature control

#### Text Books

1. Shrivastav, U. K., “Construction Planning Management”, Galgotia Publications.
2. Peurifoy, R. L., “Construction Planning, Equipment and Methods”, McGraw Hill Publication, New Delhi, 7th Edition, 2013.
3. Jha, K. N., “Construction Project Management: Theory and Practice”, Pearson Publication, New Delhi, 2012.

# **Course Structure & Syllabus of B.Tech.– Civil Engineering**

## **Applicable for Batch: 2020-24**

### **References**

1. Ahuja, H. N., “Construction Performance Control by Networks”, John Wiley & Sons, 1976.
2. Satyanarayana, B., Saxena, S. C., “Construction, Planning and Equipment”, Standard Publishers, 3rd Edition, 1985.
3. Moder, J. J., Phillips, C. R., “Project Management with CPM and PERT”, Van Nostrand Reinhold Co., 2nd Edition, 1970.

### **12. Teaching and Learning Strategy**

All materials (ppts, assignments, labs, etc.) will be uploaded in Moodle. Refer to your course in Moodle for details.



# Course Structure & Syllabus of B.Tech.– Civil Engineering

## Applicable for Batch: 2020-24

1.	<b>Department offering the course</b>	Civil Engineering
2.	<b>Course Code</b>	CEFXXX
3.	<b>Course Title</b>	Value Added Training II
4.	<b>Credits</b>	2
5.	<b>Contact Hours (L:T:P)</b>	0 0 4
6.	<b>Prerequisites (if any)</b>	Design of Reinforced Concrete Structures
7.	<b>Course Basket</b>	Skill Enhancement Course

8. **Course Summary:** Learning commercial codes **PRIMAVERA** and **ANSYS**.  
Knowledge of this course will increase the proficiency and employability of the students

9. **Course Objectives:** Increasing abilities of converting the civil engineering knowledge to solving the multi-story building analysis problem

### 10. Course Outcomes:

On completion of this course, the students will be able to

1. Learn commercial codes for different types of problems
2. Interpret the domain knowledge converting that into mathematical modelling and solving the societal problems
3. Plan several tasks in civil engineering construction domain

### 11. Curriculum Content:

#### List of Experiments

#### 1. PRIMAVERA for project planning

- 1.1. Defining Project
- 1.2. Introductory commands
- 1.3. Doing calculation using CPM PERT
- 1.4. Defining various parameters for Project time analysis
- 1.5. Drawing significant conclusions from the project calculations

#### 3. ANSYS for analyzing various civil engineering structures

- 1.1. Defining Problem statement corresponding to structural element
- 1.2. Defining Geometry
- 1.3. Defining Mathematical Model
- 1.4. Defining Numerical Model
- 1.5. Defining Boundary conditions
- 1.6. Drawing significant conclusions from stress analysis

#### Textbook(s)

3. Manual : PRIMAVERA
4. Manual : ANSYS

### 12. Teaching and Learning Strategy

All materials (ppts, assignments, labs, etc.) will be uploaded in Moodle. Refer to your course in Moodle for details.

# Course Structure & Syllabus of B.Tech.– Civil Engineering

## Applicable for Batch: 2020-24

### ELECTIVES

1.	Department offering the course	Civil Engineering
2.	Course Code	CEF341
3.	Course Title	Engineering Geology
4.	Credits	3
5.	Contact Hours (L:T:P)	2 0 2
6.	Prerequisites (if any)	Geomatics Engineering
7.	Course Basket	Discipline Elective

8. **Course Summary:** Engineering Geology covers the basic idea about the deformation of structures and the criteria to select any project site

9. **Course Objectives:** The objectives of this course are to apply geological concepts and approaches on rock engineering projects and also to use the geologic literature to establish the geotechnical framework.

#### 10. Course Outcomes:

On completion of this course, the students will be able to

1. Able to interpret the geological data and information required for the safe development of civil works.
2. Apply basic Engineering concepts to assessment and mitigation of geologic hazards such earthquakes, landslides, flooding;
3. Focus on the core activities of engineering geologists, site characterization for civil work projects
4. Distinguish the characteristic of most important geological formations and problems that may arise in various public works.
5. Understand issues concerning the geological basement and structure of a region.

#### 11. Curriculum Content:

##### Unit 1

##### Physical Geology

Geology and its importance in civil engineering projects; internal structure of the earth and its composition; Epigene and Hypogene geological agents; Weathering of rocks, Kinds of weathering; Formation of soil and its classification, Soil profile, Concept of plate tectonics and seafloor spreading.

##### Unit 2

##### Applied Mineralogy and Petrology

Definition of mineral, Classification of minerals based on chemistry such as rock forming Minerals, Economic ore minerals and industrial minerals. Silicate Structure, Igneous rocks: Mode of occurrence, Classification, Texture and Structure. Sedimentary rock: Mode of occurrence, textures and structures. Metamorphic rocks- Metamorphism, Agents of metamorphism, Types of metamorphism, Textures and Structure

##### Unit 3

##### Structural Geology

Concepts of Dip and Strike; Compass clinometer; Description of folds, Faults, Joints and Unconformities with their Types; Recognition of folds and faults in the field and its consideration in Civil Engineering projects.

##### Unit 4

##### Site selection criteria for Engineering projects

# **Course Structure & Syllabus of B.Tech.– Civil Engineering**

## **Applicable for Batch: 2020-24**

Geological site investigation, surface and subsurface explorations by geological and geo-Physical investigations, Selection of Geological site for construction of Dams and Reservoirs, Tunnels, Bridge Sites, and Highways.

### **Unit 5**

#### **Case studies**

Geological hazards such as landslides, volcanoes and earthquakes- causes, effects and remedial measures; Various case studies deal with failure of engineering projects- Reason and precaution measures.

#### **Text Books**

1. Singh, P., “Engineering Geology”, S. K. Kataria & Sons, New Delhi, 2009.
2. B.S.Satyanarayana Swamy , Engineering Geology Laboratory Manual , Dhanpat Rai Sons, New Delhi.

#### **References**

1. Reddy D. V., “Engineering Geology”, Vikas Publishing House Pvt. Ltd, Noida.
2. Varghese, P. C., “Engineering geology for Civil Engineers”, PHI Learning Pvt. Ltd., 2012.

#### **List of Experiments**

- 1 Detail Identification of minerals in hand specimen
- 2 Detail Identification of igneous rocks in hand specimen
- 3 Detail Identification of sedimentary rocks in hand specimen
- 4 Detail Identification of metamorphic rocks in hand specimen
- 5 Detail identification of minerals (thin section) under microscope
- 6 Study and Interpretation of Contour map and profile section
- 7 Solving Dip and Strike Problems
- 8 Preparation of structural maps and their interpretation

#### **12. Teaching and Learning Strategy**

All materials (ppts, assignments, labs, etc.) will be uploaded in Moodle. Refer to your course in Moodle for details.

# Course Structure & Syllabus of B.Tech.– Civil Engineering

## Applicable for Batch: 2020-24

1.	<b>Department offering the course</b>	Civil Engineering
2.	<b>Course Code</b>	CEF342
3.	<b>Course Title</b>	Hydraulics and Hydraulic Machines
4.	<b>Credits</b>	3
5.	<b>Contact Hours (L:T:P)</b>	2 0 2
6.	<b>Prerequisites (if any)</b>	Fluid Mechanics
7.	<b>Course Basket</b>	Discipline Elective

8. **Course Summary:** This course will offer knowledge about the open channel flow, pumps and turbines

9. **Course Objectives:** The objective of this course is to introduce the students to various hydraulic engineering problems like open channel flows and hydraulic machines. At the completion of the course, the student should be able to relate the theory and practice of problems in hydraulic engineering.

### 10. Course Outcomes:

On completion of this course, the students will be able to

1. Apply their knowledge of fluid mechanics in addressing problems in open channels.
2. Possess the skills to solve problems in uniform, gradually and rapidly varied flows in steady state conditions
3. Compute forces on Flat plate and Curved vanes by the impact of water Jet.
4. Solve problems related to hydraulic machineries (pumps and turbines).

### 11. Curriculum Content:

#### Unit 1

**Open Channel Flow:** Definition of open channel, Geometric properties, Uniform flows in open channels: Chezy and Manning's equation, Velocity Distribution in Open Channel. Most Economical sections: Rectangle and Trapezoidal

#### Unit 2

**Specific Energy:** Specific Energy, Specific energy curve, condition for minimum specific energy and maximum discharge, Critical flow in Rectangular channels, Problems. Gradually Varied Flow, Flow profiles, Hydraulic Jump in a rectangular channels, classification of jump.

#### Unit 3

**Impact of Jet on Vanes:** Introduction to impulse momentum equation and its applications, Force exerted by a jet on a fixed target, Derivations, Force exerted by a jet on a moving target, derivations, Force exerted by a jet on a series of a curved vanes, concept of velocity triangles, equation for work done and efficiency.

#### Unit-4

**Hydraulic Turbines:** Introduction, types and classifications, Pelton wheel, equation for work done and efficiency, Specific speed, Francis and kaplan turbine- Theory, equation for work done and efficiency, Design parameters, Draft tube.

#### Unit 5

**Centrifugal and Reciprocating Pumps:** Definition of pumps and classification, Principle of working, priming and methods, Specific speed, Work done and efficiencies of centrifugal and reciprocating pumps, Minimum starting speed, Cavitation in centrifugal pumps, multistage pumps.

### List of Experiments

# **Course Structure & Syllabus of B.Tech.– Civil Engineering**

## **Applicable for Batch: 2020-24**

- 1 Determination of Manning's roughness coefficient for a given channel bed.
- 2 Study the characteristics of Hydraulic jump.
- 3 Determination of efficiency of Pelton wheel turbine.
- 4 Determination of efficiency of Francis turbine.
- 5 Determination of efficiency of Multistage centrifugal pump.
- 6 Determination of efficiency of Reciprocating pump.
- 7 Determination of efficiency of impact of jet on vanes

### **Textbook(s):**

1. Bansal, R. K., "Fluid Mechanics and Hydraulic Machine", Lakshmi Publications, New Delhi.
2. Subramanya. K., "Flow in open Channel", Tata McGraw Hill, New Delhi.

### **Reference Books**

1. Modi, P. N., Seth, S. M., "Hydraulics and Fluid Mechanics", Standard Book House, New Delhi, 2004.
2. Jain, A.K., "Fluid Mechanics: Including Hydraulic Machines", Khanna Publishers, New Delhi, 2010.

### **12. Teaching and Learning Strategy**

All materials (ppts, assignments, labs, etc.) will be uploaded in Moodle. Refer to your course in Moodle for details.

# Course Structure & Syllabus of B.Tech.– Civil Engineering

## Applicable for Batch: 2020-24

1. Department offering the course	Civil Engineering
2. Course Code	CEF343
3. Course Title	Environmental Risk Assessment and Disaster Management
4. Credits	3
5. Contact Hours (L:T:P)	3 0 0
6. Prerequisites (if any)	None
7. Course Basket	Discipline Elective

### 8. Course Summary:

9. **Course Objectives:** The objectives of this course are to learn basics concepts of Environmental components, Impact assessment, Natural hazards and mitigation strategies.

### 10. Course Outcomes:

On completion of this course, the students will be able to

1. Identify environmental attributes, necessity and components of Impact assessment and its various methods
2. Have the complete knowledge about natural and human induced disasters.
3. Gain the idea about various mitigation measures, remedial actions to minimize the loss of resource and lives.
4. Identify the roles of various Government and non Government agencies for enforcing Environmental laws and disaster mitigations

### 11. Curriculum Content:

#### Unit 1

**Environmental attributes and assessment:** Introduction and Scope utility of the Environmental Impact Assessment process, expanded and narrowed scope of Environmental Impact Assessment, impacts of development activities, planning and management of impact studies. Environmental attributes and environmental indices and indicators, environmental assessment, methods and techniques, matrices, network and checklist methods, prediction techniques for quality of environmental attributes

#### Unit 2

**Environmental Impact and Risk Assessment:** Impact evaluation, assessment of impact on air, water, soil and ground water, noise, biological environment. Assessment of impact on socio-economic environment, evaluation methods, mitigation measures. Health risk assessment, Hazard identification, toxicology and dose response characterization, exposure characterization, risk characterization, uncertainty in estimates. Risk evaluation, risk acceptance, basic principles of health risk management.

#### Unit 3

**Understanding Disasters:** Meaning, nature, characteristics and types of Disasters, Causes and effects, Disaster: A Global View, Disaster Profile of India, The Disaster Management cycle. Geological and Mountain Area Disasters: Earthquakes, Volcanic eruption, Landslides, Snow Avalanches, d and Water Related Natural Disaster: Floods and Flash Floods, Droughts Cyclones, Tsunamis, Man Made Disasters: Understanding Man Made Disasters: Fires and Forest Fires, Nuclear, Biological and Chemical disaster, Road Accidents.

#### Unit 4

**Disaster Risk Reduction and Role of various Organizations:** Disaster Management: Prevention, Preparedness and Mitigation. Roles and responsibilities of different agencies and Government. Technologies for Disaster Management. Disaster Mitigation Strategies.

# **Course Structure & Syllabus of B.Tech.– Civil Engineering**

## **Applicable for Batch: 2020-24**

### **Unit 5**

**Disasters, Environment and Development:** Factors affecting vulnerability such as impact of developmental projects and environmental modifications (including of dams, land use changes, urbanization etc.), sustainable and environmental friendly recovery; reconstruction and development methods.

### **Text Books**

1. CK Rajan, N Pandharinath – 2009, Earth and Atmospheric Disaster Management: Nature and Man-made, BS publications
2. Pradeep Sahni, 2004, Disaster Risk Reduction in South Asia, Prentice Hall.
3. Singh B.K., 2008, Handbook of Disaster Management: Techniques & Guidelines, Rajat Publication.
4. Ghosh G.K., 2006, Disaster Management, APH Publishing Corporation.

### **References**

1. Kenneth, W., Werner, F. C., Davis W. T., “Air Pollution: Its Origin and Control”, 3<sup>rd</sup> Edition, Prentice Hall.
2. Mishra, P. C., “Fundamentals of Air and Water Pollution”, South Asia Books, 1990.
3. Masters, G., “Introduction to Environmental Engineering and Science”, Prentice Hall of India, 2004.
4. Singh B.K., 2008, Handbook of Disaster Management: Techniques & Guidelines, Rajat Publication.

### **12. Teaching and Learning Strategy**

All materials (ppts, assignments, labs, etc.) will be uploaded in Moodle. Refer to your course in Moodle for details.

# Course Structure & Syllabus of B.Tech.– Civil Engineering

## Applicable for Batch: 2020-24

1.	<b>Department offering the course</b>	Civil Engineering
2.	<b>Course Code</b>	CEF344
3.	<b>Course Title</b>	Hydraulic Structures and Hydropower Engineering
4.	<b>Credits</b>	3
5.	<b>Contact Hours (L:T:P)</b>	2 1 0
6.	<b>Prerequisites (if any)</b>	Fluid Mechanics
7.	<b>Course Basket</b>	Discipline Elective

8. **Course Summary:** This course will impart knowledge about hydraulic structures and the aspects of hydropower engineering.

9. **Course Objectives:** The course enables the student to learn about various hydraulic structures such as dams, spillways, head works, canal structures etc. This course will help the student to understand about the various aspects of hydropower plants such as their types and various intake structures

### 10. Course Outcomes:

On completion of this course, the students will be able to

1. Principles of reservoir operation, along with their types and the criteria for selection of site
2. Classification and design of various types of dams
3. Classification and design of various types of head works and canal structures.
4. Classification and design of various types of spillways along with the basic idea about the hydropower plant
5. Types of hydropower plants and various intake structures

### 11. Curriculum Content:

#### Unit 1

##### Introduction to Reservoirs

Hydraulic structures for water resources projects. Types of reservoir, selection of site for reservoir, investigation of reservoir and damsite, Definition of general term. Reservoir capacity from mass curve. Life of reservoir and its computation. Water losses from reservoir. Principles of reservoir operation.

#### Unit 2

##### Embankment and Gravity dams

Embankment Dam: Types, design considerations, seepage analysis and control, stability analysis, construction techniques. Gravity Dam: Forces acting on failure of a gravity dam, stress analysis, elementary profile, design of gravity dam, other functional features of a gravity dam.

#### Unit 3

##### Head works and Canal Structures

Layout, components, canal regulators: function and types of regulators. Canal drops component and types of canal drop. Cross drainage works: classification, canal outlets. Hydraulic design for a notch type of drop.

#### Unit 4

##### Spillways and hydropower plant

Types and their design, spillwaygates, Cavitation, Aerators and energy dissipation (terminal structures). Terms relating to hydropower, basic design aspects of different unit of hydropower plant

#### Unit 5: Types of hydropower plants and intake structures



# **Course Structure & Syllabus of B.Tech.– Civil Engineering**

## **Applicable for Batch: 2020-24**

Classification of hydropower plants, Base and peak load hydropower plants, Run-of- river plants  
Storage power plant and Pumped-storage power plants, Intake structure: functions, location and  
types, penstocks

### **Textbook(s):**

1. Garg, S. K., “Irrigation engineering and hydraulic structures”, Khanna Publishers, New Delhi, 23<sup>rd</sup> Edition, 2009.
2. Singh, B., “Fundamentals of Irrigation Engineering”, Nem Chand & Bros, 9th Edition, 1997.

### **Reference Books:**

- 1 Asawa, G. L., “Irrigation Engineering”, New Age International, 2nd Edition, 1996.  
Sahasra Budhe, “Irrigation Engineering and Hydraulic Structures”, Dhanpat Rai Publication  
Ltd., New Delhi.
- 2 Chow, V. T., “Open Channel Hydraulics”, McGraw-Hill, 1959.

### **12. Teaching and Learning Strategy**

All materials (ppts, assignments, labs, etc.) will be uploaded in Moodle. Refer to your course in Moodle for details.

# Course Structure & Syllabus of B.Tech.– Civil Engineering

## Applicable for Batch: 2020-24

1.	<b>Department offering the course</b>	Civil Engineering
2.	<b>Course Code</b>	CEF345
3.	<b>Course Title</b>	Green Buildings and Energy Conservation
4.	<b>Credits</b>	3
5.	<b>Contact Hours (L:T: P)</b>	3 0 0
6.	<b>Prerequisites (if any)</b>	Building Design, Construction & Drawing (CAS)
7.	<b>Course Basket</b>	Discipline Elective

8. **Course Summary:** Green Building and energy conservation describes about the various aspects of green building in terms of their design and material uses.

9. **Course Objectives:** The Objective of the course is to learn basics of green building concepts, design and energy efficiency.

### 10. Course Outcome

On completion of this course, the students will be able to

1. Green building concepts and design
2. Energy savings and efficient use
3. Indoor Environment quality and maintenance

### 11. Curriculum Content

#### Unit 1

**Introduction:** Definition of Green Buildings, Importance of Green Buildings, Key requisites for constructing a Green Building, Green Building Concepts and Practices in India and Worldwide, Green Building Councils in India and Worldwide, Green Building Rating Systems

#### Unit 2

**Green Building Design Features:** Sustainable Sites, Material and Resources, Water Efficiency, Energy Efficiency, Indoor Environment Quality, **Sustainable Sites;** Pollution Prevention, Site Selection, Transportation, Storm water Design, etc

#### Unit 3

**Material and Resources:** Reducing, Reusing, Recycling. **Water Efficiency;** Water Use Reduction, Water Efficient Landscaping, Wastewater Technologies

#### Unit 4

**Energy Efficiency:** Optimize Energy Performance, On-site Renewable Energy, Refrigerant Management, Measurement and Verification, Green Power.

#### UNIT 5

**Indoor Environment Quality:** Indoor Air Quality Performance, Increased Ventilation, Low-Emitting Materials, Thermal Comfort, Controllability of Systems

#### Text Books:

1. Handbook on Green Practices published by Indian Society of Heating Refrigerating and Air conditioning Engineers, 2009.
2. IGBC-LEED for New construction and Major Renovations, Version 3.0, 2014.

#### Recommended References:

1. Green Building Illustrated by Francis D. K. Ching and Ian M. Shapiro, 2014
2. Complete Guide to Green Buildings by Trish riley
3. Standard for the design for High Performance Green Buildings by Kent Peterson, 2009

# **Course Structure & Syllabus of B.Tech.– Civil Engineering**

## **Applicable for Batch: 2020-24**

### **12. Teaching and Learning Strategy**

All materials (ppts, assignments, labs, etc.) will be uploaded in Moodle. Refer to your course in Moodle for details.

# Course Structure & Syllabus of B.Tech.– Civil Engineering

## Applicable for Batch: 2020-24

1.	<b>Department offering the course</b>	Civil Engineering
2.	<b>Course Code</b>	CEF346
3.	<b>Course Title</b>	Water and Land Management
4.	<b>Credits</b>	3
5.	<b>Contact Hours (L:T:P)</b>	3 0 0
6.	<b>Prerequisites (if any)</b>	Hydrology and Irrigation Engineering
7.	<b>Course Basket</b>	Discipline Elective

8. **Course Summary:** Course describes about the various irrigation and land use aspects of the land as a resource which subsequently plays role in design of irrigation systems.

9. **Course Objectives:** The objectives of this course are to study the problems in irrigation system in our country and different types of irrigation methods. Also to understand the norms and method of land levelling for irrigation and know about drought management and water management.

### 10. **Course Outcomes:**

On completion of this course, the students will be able to

1. Understand Basic concepts of water and land management for irrigation.
2. Learn Different methods of Irrigation.
3. Learn the Drought and Water Management Policy.
4. Compute the Reservoir capacity by various methods and principles of reservoir operation.

### 11. **Curriculum Content:**

#### **Unit 1**

#### **Problems of irrigation systems in India & Soil, Water Plant Relationship**

**Introduction,** Problems of irrigation systems in India, Soil and Land Irrigability, classification, Basic concepts of diagnostic analysis. Evapotranspiration, crop coefficient, effective rainfall, crop water demand and availability, irrigation efficiencies.

#### **Unit 2**

**Irrigation scheduling & Micro level Planning:** Irrigation scheduling, Stressed irrigation, drought and water management policy during drought. Micro level Planning for any canal/tube well system, Evaluation of chak planning and design.

#### **Unit 3**

**Water application methods & Operation and maintenance of irrigation system:** Water application methods, Border irrigation, basin irrigation, furrow irrigation, sprinkler and drip irrigation. Operation and maintenance of irrigation system, rotational water distribution systems- arabandi. Evaluation of irrigation project's performance and improvement.

#### **Unit4**

**Evaluation and status of land development:** Evaluation and status of land development in irrigated commands, Norms of land leveling, methods of land leveling. Plane method or centroid method, contour adjustment method.

#### **Unit5**

**Water Management for Irrigation:** Irrigation behaviour and decision making, Attitudes and their influence on irrigation management, night irrigation, participatory irrigation management, irrigation organizations.

#### **Textbook(s):**

1. Michael, A. M., "Irrigation: Theory and Practice", Vikas Publishing House Pvt Ltd, New

# **Course Structure & Syllabus of B.Tech.– Civil Engineering**

## **Applicable for Batch: 2020-24**

- Delhi, 2008.
2. Allen, R. G., Pereira, L. S., Raes, D., Smith, M., “FAO Irrigation and Drainage Paper: Crop Evapo-transpiration (guidelines for computing crop water requirements)”, No. 56, Rome, Italy.
  3. FAO Irrigation and Drainage Paper no. 24 & 58, Rome, Italy.
  4. Asawa, G. L., “Irrigation and Water Resources Engineering”, New Age International, New Delhi, 2006.
  5. Mazumdar, S. K., “Irrigation Engineering”, Tata McGraw Hill Publication, New Delhi.

### **Reference Books:**

1. Diagnostic Analysis of Minor irrigation scheme, Publication no. 11, WALMI, Aurangabad (Maharashtra).
2. Application of soil survey in Irrigation Water Management, Publication no. 21, WALMI, Aurangabad (Maharashtra).

### **12. Teaching and Learning Strategy**

All materials (ppts, assignments, labs, etc.) will be uploaded in Moodle. Refer to your course in Moodle for details.

# Course Structure & Syllabus of B.Tech.– Civil Engineering

## Applicable for Batch: 2020-24

1.	<b>Department offering the course</b>	Civil Engineering
2.	<b>Course Code</b>	CEF347
3.	<b>Course Title</b>	Port & Harbour Engineering
4.	<b>Credits</b>	3
5.	<b>Contact Hours (L:T)</b>	2 1 0
6.	<b>Prerequisites (if any)</b>	Transportation Engineering II
7.	<b>Course Basket</b>	Discipline Elective

8. **Course Summary:** Ports and Harbor Engineering covers the planning aspects and the design and repair aspect of facilities essentially required in the port and harbour areas.

9. **Course Objectives:** The objectives of this course is to make students aware about latest mode of transportation, development of this mode in India and to enable students to learn the concepts of harbor planning.

### 10. **Course Outcomes:**

On completion of this course, the students will be able to

1. Working of rapidly growing transport network,
2. Designing of docks and harbors.
3. Managing safety issues in ports.
4. Dredging and Coastal Protection

### 11. **Curriculum Content:**

#### **Unit 1**

**National Waterways:** Inland water transportation in India, classification of waterways, economics of inland waterways transportation, national waterways

#### **Unit 2**

**Harbour Planning:** Types of water transportation, water transportation in India, requirements of ports and harbours, classification of harbours, selection of site and planning of harbours, location of harbour, traffic estimation, master plan, ship characteristics, harbour design, turning basin, harbour entrances

#### **Unit 3**

**Docks and Repair Facilities:** Type of docks, its location and number, Site investigations – hydrographic survey, topographic survey, soil investigations, current observations, tidal observations, Design and construction of breakwaters, berthing structures - jetties, fenders, piers, wharves, dolphins, trestle, moles, Harbour docks, use of wet docks, design of wet docks, repair docks, lift docks, dry docks, keel and bilge blocking, construction of dry docks, gates for dry docks

#### **Unit 4**

**Port facilities:** Port development, port planning, port building facilities, transit sheds, warehouses, cargo handling facilities, container handling terminal facilities, shipping terminals, inland port facilities. Inland waterways, Inland water transportation in India, classification of waterways, economics of inland waterways transportation, national waterways.

#### **Unit 5**

**Dredging and Coastal Protection:** Classification, types of dredgers, choice of dredger, uses of dredged materials, coastal erosion and protection, sea wall, revetment, bulkhead, coastal zone and beach profile.

#### **Text Books**

1. Bindra, S.P., “Docks and Harbour Engineering”, Dhanpat Rai publications, 2012

# **Course Structure & Syllabus of B.Tech.– Civil Engineering**

## **Applicable for Batch: 2020-24**

2. Srinivasan, R., “Harbour, dock and tunnel engineering”, Charotar publishing house pvt ltd, 2015
3. Oza, Gautam H. and Oza, Hasmukh P., “Dock & Harbour Engineering”, Charotar publishinghouse pvt ltd, 2012

### **References**

1. Subramanian, K.P., “Highway, Railway, Airport and Harbour Engineering”, Scitech publications (India) pvt.. ltd.

### **12. Teaching and Learning Strategy**

All materials (ppts, assignments, labs, etc.) will be uploaded in Moodle. Refer to your course in Moodle for details.

# Course Structure & Syllabus of B.Tech.– Civil Engineering

## Applicable for Batch: 2020-24

1.	Department offering the course	Civil Engineering
2.	Course Code	CEF348
3.	Course Title	Air and Water Pollution
4.	Credits	3
5.	Contact Hours (L:T:P)	3 0 0
6.	Prerequisites (if any)	Water Supply Engineering
7.	Course Basket	Discipline Elective

8. **Course Summary:** Course includes evaluation of various parameters of air and water pollution

9. **Course Objectives:** The objective of this course is to learn the knowledge for various air and water pollutants, dispersion of the pollutants, mitigations measures, quality improvement and various standards.

### 10. Course Outcomes:

On completion of this course, the students will be able to

1. Identify various types of air pollutants, interactions and chemistry
2. Have the complete knowledge about pollutant source, transport mechanism, monitoring and control technologies.
3. Gain the idea about pollutant monitoring organizations, environmental laws, and implementation mechanisms
4. Gain the idea about pollutant monitoring organizations, environmental laws, and implementation mechanisms

### 11. Curriculum Content:

#### Unit 1

**Introduction:** Introduction and scope, air pollutant and types, classification, Dispersion and interaction of pollutants, Air pollutant chemistry and interactions at various atmospheric levels, Aerosols and its characteristics, noise pollution

#### Unit 2

**Measurement of Air Quality and control of air pollution:** Overview of Air quality, Mass balance approaches, Box model approaches, Gaussian plume model, regression model. Air quality dispersion-modelling approaches, Emission inventory, Air pollution monitoring and analysis, Different measurement methods, Key meteorological data, Plume shape, Air quality indices, Control technologies.

#### Unit 3

**Overview of Water Pollution:** Physico-chemical properties of water, molecular structure, common sources of water pollution, surface, ground, Ocean water pollution, water pollutant chemistry, pollutant transport, tracer kinetics, Eutrophication.

#### Unit-4

**Water Pollution measurement and Treatment:** Physical, chemical, biological quality parameters, quality indices for surface and ground water, interpretation of quality indices, numerical modeling approaches, treatment-primary, secondary and tertiary. Oxidation pond.

#### Unit- 5

**Impact of air and water quality, regulations, standards:** Air and water pollution versus health risk and global climate change, Ecological risk, Air and water quality standards, National and international regulations and legislations. Reclamation of water bodies, National and International regulatory bodies, Mitigation strategies.



# **Course Structure & Syllabus of B.Tech.– Civil Engineering**

## **Applicable for Batch: 2020-24**

### **Textbook(s):**

1. Mishra, P. C., “Fundamentals of Air and Water Pollution”, APH Publishing Corporation, 2008.
2. Kenneth, W., Warner, F. C. and Davis W. T., “Air Pollution, Its Origin and Control”, Prentice Hall, 3<sup>rd</sup> Edition, 1997.

### **Reference Books:**

1. Davis, M. L. and Cornwell, D. A., “Introduction to Environmental Engineering”, McGraw-Hill, 5<sup>th</sup> Edition, 2012.
2. Chin, D. A., “Water Quality Engineering in Natural Systems: Fate and Transport Processes in the Water Environment, John Wiley, 2<sup>nd</sup> Edition, 2012.

### **12. Teaching and Learning Strategy**

All materials (ppts, assignments, labs, etc.) will be uploaded in Moodle. Refer to your course in Moodle for details.

# Course Structure & Syllabus of B.Tech.– Civil Engineering

## Applicable for Batch: 2020-24

1.	Department offering the course	Civil Engineering
2.	Course Code	CEF349
3.	Course Title	Remote Sensing and Image Processing
4.	Credits	3
5.	Contact Hours (L:T:P)	2 0 2
6.	Prerequisites (if any)	Engineering Geology
7.	Course Basket	Departmental Elective

8. **Course Summary:** Remote Sensing and Image Processing covers the understanding about satellite image, Aerial Photography and concept of Electromagnetic spectrum

9. **Course Objectives:** The course objective is to make students aware of the photogrammetry and the concepts of stereoscopy, also to learn photo interpretation techniques.

### 10. Course Outcomes(Old):

On completion of this course, the students will be able to

1. Understand the basic concepts of remote sensing for better analysis of satellite data.
2. Explain the basic concepts of aerial photograph for better analysis of aerial images and photographs.
3. Apply the concept of parallax.
4. Analyse the 3-D interpretation of aerial images.
5. Apply the knowledge of remote sensing and photogrammetry to solve the real time engineering projects by the use of GIS.

### 11. Curriculum Content:

#### Unit 1

**Principles of Remote Sensing:** Sources of Energy, active and passive radiation, Electromagnetic spectrum, radiation laws, interaction of energy with atmosphere scattering, absorption, atmospheric windows, and interaction of EMR with earth surface features-spectral signatures, stages in remote sensing.

#### Unit 2

**Fundamentals of Aerial Photogrammetric:** Fundamentals of Aerial Photogrammetry: Introduction, Classification, Aerial Camera, Films and Filters, Geometrical elements of vertical photograph, Scale, Relief Displacements, photo and ground coordinates

#### Unit 3

**Stereoscopy:** Stereoscopic vision, Lens and Mirror stereoscope, parallax equations, Parallax bar, Measurement of heights and heights and slopes, Ground control for aerial Photography, Topo sheets, Photographs and Mosaics.

#### Unit 4

**Aerial Photo Interpretation:** Basic considerations, principles of photo interpretation, Characteristics of photographic images, Techniques of photo interpretation, photo interpretation key, Ground truth verification.

# **Course Structure & Syllabus of B.Tech.– Civil Engineering**

## **Applicable for Batch: 2020-24**

### **Unit 5**

#### ***Image Processing***

*Image processing software, digital data products and their characteristics, digital image formats, colour image generation, initial data statistics, histogram and scatter plot, mosaicing, pre-processing, image enhancement, contrast stretching, noise removal, low and high pass filters, other filters, edge detection, texture image, Ratio and NDVI images, PCA and its uses*

**Applications in Civil Engineering:** Water Resources, Watershed Management, Environmental studies, Land use and Land Cover mapping – Urban sprawl and Transportation Network mapping, Geology and soil mapping, Ground Water Exploration.

#### **List of Experiments**

1. Testing Stereovision with test card
2. Finding stereoscopic acuity
3. Determination of photo scale
4. Mirror Stereoscope – Base lining and Orientation of Aerial Photographs
5. Aerial photograph i) direct tracing of features for Urban planning and Highway planning  
ii) Radial line triangulation
6. Study of different types of satellite data products
7. Visual interpretation of satellite images of different resolutions
8. Study of aerial photographs in 3D using stereoscope
9. Extraction of thematic information from satellite images
10. Use of satellite images for land use mapping

#### **Text Books**

1. Lillesand, T. M., Kiefer, R.W., Chipman, J. W., “Remote Sensing and Image Interpretation”, John Wiley & Sons Limited, Canada, 5th Edition, 2004.
2. Punmia, B. C., Jain, A. K., Jain, A. K., “Surveying”, Laxmi Publications Pvt. Ltd., New Delhi, Vol. II, 12th Edition, 2005.

#### **References**

1. Wolf P. R., Elements of Photogrammetry with Application in GIS, McGraw Hill International Book Company, 2013.
2. Moffitt, Francis H. & Mikhail, Edward M., Photogrammetry, Harper and Row Publishers, 1980.

### **12. Teaching and Learning Strategy**

All materials (ppts, assignments, labs, etc.) will be uploaded in Moodle. Refer to your course in Moodle for details.

# Course Structure & Syllabus of B.Tech.– Civil Engineering

## Applicable for Batch: 2020-24

1.	Department offering the course	Civil Engineering
2.	Course Code	CEF351
3.	Course Title	Prestressed Concrete
4.	Credits	3
5.	Contact Hours (L:T:P)	2 1 0
6.	Prerequisites (if any)	Design of Reinforced Concrete Structures
7.	Course Basket	Discipline Elective

8. **Course Summary:** Analysis of stresses in concrete due to prestress and design based on that.

9. **Course Objectives:** The course objective is to understand the need for prestressed concrete structures and to understand pre-tensioning, post-tensioning, full and partial prestressing concepts.

### 10. Course Outcomes:

On completion of this course, the students will be able to

1. Understand the prestressed concrete, prestressing concrete principles in addition to the difference of traditional concrete and pre stressed concrete.
2. Analyze a Pre-stressed Concrete section
3. Design and construct reinforced earth retaining structures.
4. Design pre-tensioned and post tensioned beams for flexure and shear

### 11. Curriculum Content

#### Unit 1

**Materials, Basic Principles of Pre-Stressing, Prestressing Systems:** Basic concepts of prestressing, High strength concrete and steel, Stress-strain characteristics and properties, Various prestressing systems, Pre-tensioning and Post- tensioning systems with anchorages, Advantages and limitations of prestressed concrete

#### Unit 2

**Analysis of Sections for Flexure:** Basic assumptions, Analysis of stresses in concrete due to pre-stress and loads for different types of cross section, Pressure line or thrust line, Cable profile, Concept of load balancing, Cracking moment

#### Unit 3

**Losses of Pre-Stress & Deflections:** Nature of losses in pre-stress, various losses encountered in pre-tensioning and post tensioning methods, Deflection, Factors influencing deflection, Elastic deflection under transfer loads and due to different cable profile. Deflections limits as per IS-1343. Effects of creep on deflection, crack widths

#### Unit 4

**Flexural and Shear Strength of Prestressed Concrete Sections:** Types of flexural failure, IS code recommendations for flexure, Ultimate flexural strength of section. Shear and principal stresses, Ultimate shear resistance of prestressed concrete members, Shear reinforcement

#### Unit- 5

**Transfer of Prestress in Pre tensioned Members and Anchorage Zone Stresses in Post Tensioned Members:** Transmission of pre-stress in pre-tensioned members, Transmission length, Bond stresses, Codal provisions for bond and transmission length, Anchorage stress in post- tensioned member. Bearing stress and bursting tensile force, IS code provisions.

### Text Books

# **Course Structure & Syllabus of B.Tech.– Civil Engineering**

## **Applicable for Batch: 2020-24**

1. Raju, N. K., “Pre-stressed concrete”, Tata McGraw Hill, New Delhi, 1st Edition, 2012.
2. Ramamrutham, S., “Pre-stressed Concrete”, Dhanpat Rai Publishing Company (P) Ltd., New Delhi, 2003.
3. Lin, T. Y., Burns, N. H., “Design of pre- stressed Concrete Structures”, John Wiley and Sons. New York, 3rd Edition, 1981.

### **References**

1. Pre stressed concrete by N.RajaGopalan, Nerosa Publishing house

### **12. Teaching and Learning Strategy**

All materials (ppts, assignments, labs, etc.) will be uploaded in Moodle. Refer to your course in Moodle for details.

# Course Structure & Syllabus of B.Tech.– Civil Engineering

## Applicable for Batch: 2020-24

1.	<b>Department offering the course</b>	Civil Engineering
2.	<b>Course Code</b>	CEF352
3.	<b>Course Title</b>	Earthquake Engineering
4.	<b>Credits (L:T:P:C)</b>	3
5.	<b>Contact Hours (L:T:P)</b>	2 1 0
6.	<b>Prerequisites (if any)</b>	Design of Reinforced Concrete Structures
7.	<b>Course Basket</b>	Discipline Core

8. **Course Summary:** Earthquake engineering includes mechanics behind the behaviour of buildings during earthquake

9. **Course Objectives:** The course is designed to incorporate earthquake effects in analysis of structures and to learn about seismicity and various parameters related to measurement of earthquake effects.

### 10. Course Outcomes:

On completion of this course, the students will be able to

CO1: Understand basic terminologies & concepts of earthquake engineering.

CO2: Solve SDOF problems.

CO3: Explain effects of earthquake on ground and structure, landslides and cracks & collapse of structures.

CO4: Determine mode shapes for MDOF systems.

CO5: Evaluate lateral forces acting on a structure by using codal provisions.

### 11. Curriculum Content

#### Unit 1

**Seismology:** Earth's interior and plate tectonics, Global Seismic Belts, Seismic waves, Earthquake measurement parameters, Indian seismic zoning map, effect of soil on earthquake.

#### Unit 2

**Single degree of freedom systems:** Un-damped and Damped free vibration with viscous damping, forced vibrations, Steady state, Vibration Isolation, Response of un-damped systems to time dependent force functions (Pulse/impulses), Duhamel's Integral, Response spectrum, DVA spectrum and construction of design spectrum.

#### Unit 3

**Earthquake Effects:** Ground failures, Local site effects, Effects on ground and structure, Land-slides, Cracks & collapse of structures.

#### Unit 4

**Multi Degree of Freedom Systems:** Mode shapes, Orthogonality of modes, of frequency and mode shapes by Holzer method, Stodola Method, Rayleigh's method.

#### Unit-5

**Earthquake Excitation:** Equivalent lateral force for Earthquake, Response spectrum method for analysis of structures and its codal provisions, codal provisions for seismic isolation, Soil structure interaction.

# **Course Structure & Syllabus of B.Tech.– Civil Engineering**

## **Applicable for Batch: 2020-24**

### **Text Books**

1. Chopra, A.K., “Dynamic of structures”, Prentice Hall,4<sup>th</sup> Edition,2011.
2. Paz, M., Leigh, W., “Structural Dynamics: Theory of Computation”, Springer,5<sup>th</sup> edition, 2006.

### **References**

1. Krishna, J., Chandrasekran A. K. and Chandra B. “Elements of Earthquake Engineering”, South Asia Publisher, New Delhi,2<sup>nd</sup> edition.
2. *S. L. Kramer, “Geotechnical Earthquake Engineering”, Prentice Hall International Series in Civil Engineering and Engineering Mechanics.*
3. *Indian Standard Code - IS:1893*

### **12. Teaching and Learning Strategy**

All materials (ppts, assignments, labs, etc.) will be uploaded in Moodle. Refer to your course in Moodle for details.

# Course Structure & Syllabus of B.Tech.– Civil Engineering

## Applicable for Batch: 2020-24

1.	Department offering the course	Civil Engineering
2.	Course Code	CEF353
3.	Course Title	Traffic Engineering and Management
4.	Credits (C)	3
5.	Contact Hours (L:T)	2:0:2
6.	Prerequisites (if any)	Transportation Engineering-I
7.	Course Basket	Discipline Elective

8. **Course Summary:** Traffic Engineering management covers the design of traffic facilities like signage, signals, intersections and also allows to give alternatives in order to manage urban traffic.

9. **Course Objectives:** The objectives of this course is to familiarize the students with the concepts of transportation planning and analysis and to ensure that students are able to use the knowledge in solving real time problems in traffic engineering field.

### 10. Course Outcomes:

On completion of this course, the students will be able to

1. Apply the advanced concepts of traffic engineering making them able to design various traffic facilities.
2. Analyze techniques of travel demand and transportation planning.
3. Analyze traffic flow characteristics
4. Understand road intersection and planning

### 11. Curriculum Content

#### Unit 1

**Fundamentals of traffic engineering:** Characteristics of traffic engineering elements- vehicle, driver, road; Fundamentals of traffic flow- speed, density, flow and their relationship.

#### Unit 2

**Traffic flow characteristics:** Uninterrupted traffic flow- data collection, different models related to traffic flow; Interrupted traffic flow- shock wave, flow at signalized and un-signalized intersections; Delay and queue analysis.

#### Unit 3

**Traffic facilities:** Intersections – signalized and un-signalized. Interchanges – types, warrant. Parking – different types, Road signs, Road markings, Bus terminals.

#### Unit 4

**Transportation planning process:** Goals, objectives, Transportation needs, Generation, evaluation of alternatives and their implementation.

#### Unit 5

**Travel demand analysis:** Introduction, nature and analysis of travel demand, Data collection, Four stage transportation models, Trip generation, trip distribution, modal split and traffic assignment.

### List of Experiments

1. Spot speed study using speed Gun.
2. Speed –density linear relationship using Speed Gun.
3. Two Phase signal design using video data at an intersection.
4. Trip Generation analysis, using regression method.
5. Parking study characteristics.
6. Modal Choice using binary logit model using data of O-D survey.



# **Course Structure & Syllabus of B.Tech.– Civil Engineering**

## **Applicable for Batch: 2020-24**

### **Text Books**

1. Chakroborty, P., Das, A., “Principle of Transportation Engineering”, Prentice Hall of India Pvt. Ltd.
2. Flaherty, C. A. O., “Transport Planning and Traffic Engineering”, Butterworth-Heineman.

### **References**

1. Roger P. Roess William R.McShane & Elena S. Prassas, Traffic Engineering, Prentice – Hall, 1990.

### **12. Teaching and Learning Strategy**

All materials (ppts, assignments, labs, etc.) will be uploaded in Moodle. Refer to your course in Moodle for details.

# Course Structure & Syllabus of B.Tech.– Civil Engineering

## Applicable for Batch: 2020-24

1.	<b>Department offering the course</b>	Civil Engineering
2.	<b>Course Code</b>	CEF441
3.	<b>Course Title</b>	Advanced Highway Engineering
4.	<b>Credits</b>	3
5.	<b>Contact Hours (L:T)</b>	2 1 0
6.	<b>Prerequisites (if any)</b>	Transportation Engineering-I
7.	<b>Course Basket</b>	Discipline Elective

8. **Course Summary:** Advanced Transportation covers the design theory of rigid and flexible pavements

9. **Course Objective:** Students should be able to classify, analyze and design highways

10. **Course Outcomes:**

On completion of this course, the students will be able to

1. Compare between different models of Financial Planning of Highways in India.
2. Design Bituminous Mixes based on Marshall Mix Design Method.
3. Classify the different types of distresses in Flexible Pavements.
4. Classify the different types of distresses in Rigid Pavements.
5. Identify various construction techniques suitable for different types of road construction.

11. **Curriculum Content:**

### Unit 1

**Financial Planning of Highways:** Different Modes of Highway Projects *Public Private Partnership* (PPP), *Build Transfer* (BT), *Build Operate Transfer* (BOT), *Build Own Operate Transfer* (BOOT), *Operation & Maintenance* (O&M), *Rehabilitate Own Operate* (ROT), *Rehabilitate Own Operate Transfer* (ROOT), *Design Build Operate* (DBO), *Design Build Finance Operate & Transfer* (DBFOT), *Engineering Procurement Construction* (EPC) & *Performance Based Contract* (PBC), Economic Evaluation of highway projects, Vehicle Operating Cost.

### Unit 2

**Bituminous Mix Design:** Bituminous Mix design Methods (Marshall, Hubbard Field and Hveem), Soil Stabilized Roads: Properties of Soil- Aggregate mixtures, Proportioning, types of stabilization, advantages and limitation, Highway drainage- Surface and Sub surface drainage.

### Unit 3

**Pavement Distresses in Flexible Pavements & Measurement:** Surface Defects - Fatty Surface, Bleeding, Delamination, Smooth Surface, Streaking Surface, Hungry Surface, Polished aggregate. Cracks – Block Cracks, Alligator cracks, Edge Cracks, Edge Fatigue Crack, Longitudinal & Transverse Cracks, Fatigue Cracks, slippage crack, Reflective Cracking, Thermal Cracking. Deformation- Rutting, Corrugation, Shoving, Settlements, Upheavals. Disintegration- Pumping, Raveling, Pot Holes, Polished Aggregate. Benkelman Beam Deflection as per IRC-81-1997, Light Weight Deflectometer, Falling Weight Deflectometer, B.I. & I.R.I indexes.

### Unit 4

**Pavement Distresses in Rigid Pavements & Measurement:** Cross cracks, Spalling at joints and corners, Transverse cracks, Patching, Longitudinal crack, Raveling, Pumping & Water Bleeding, Shrinkage cracks, Distortion, Settlement or Faulting, Corner cracking, durability cracking, Polished

# **Course Structure & Syllabus of B.Tech.– Civil Engineering**

## **Applicable for Batch: 2020-24**

aggregate, Popouts, Blowups, Joint Seal Damage, Shattered slab, scaling, Map cracking & Crazing, Contaminants.

### **Unit 5**

**Highway Construction:** Construction of *Slope Subgrade Embankment*, Water bound Macadam road, Bituminous Pavements, Concrete Roads. Reinforced Concrete Roads, Prestressed Concrete Pavements. Introduction to MORTH Guidelines for highway construction.

### **Text Books & Relevant Codes**

1. Yoder, E. J., M. W. Witczak “Principle of Pavement Design”, Wiley, 2nd Edition. (2011).
2. Huang, Y.H., “Pavement Analysis and Design” Prentice Hall. 2nd edition (2008).
3. MORTH – Ministry of Road Transport & Highways, “Pocket Book for Highway Engineers”, Indian Roads Congress, New Delhi, 2019.
4. IRC SP 30: 2019 – Manual on Economic Evaluation of Highway Projects in India (Third Edition), Indian Roads Congress, New Delhi, 2019.
5. IRC:81-1997 Guidelines for Strengthening of Flexible Road Pavements Using Benkelman Beam Deflection Technique (First Revision) Indian Roads Congress, New Delhi, 1997.
6. IRC:115-2014 Guidelines for Structural Evaluation and Strengthening of Flexible Road Pavements Using Falling Weight Deflectometer (FWD) Technique” ) Indian Roads Congress, New Delhi, 2014.

### **References**

1. Khanna, S. K., Justo, C. E. G., “Highway Engineering”, Nem Chand and Bros, 2001.
2. Statinary Off., H. M., “Bituminous Material in Road Construction”, Road Research Laboratory, 1962.
3. Kerbs, R. D., and Walker, R. D., “Highway Materials”, McGraw-Hill, 1971.

### **12. Teaching and Learning Strategy**

All materials (ppts, assignments, labs, etc.) will be uploaded in Moodle. Refer to your course in Moodle for details.

**Course Structure & Syllabus of B.Tech.– Civil Engineering  
Applicable for Batch: 2020-24**

# Course Structure & Syllabus of B.Tech.– Civil Engineering

## Applicable for Batch: 2020-24

1.	<b>Department offering the course</b>	Civil Engineering
2.	<b>Course Code</b>	CEF442
3.	<b>Course Title</b>	Bridge Engineering
4.	<b>Credits (L:T:P:C)</b>	3
5.	<b>Contact Hours (L:T:P)</b>	2 1 0
6.	<b>Prerequisites (if any)</b>	Design of Reinforced Concrete Structures
7.	<b>Course Basket</b>	Discipline Elective

8. **Course Summary:** Includes analysis and design of Bridges

9. **Course Objectives:** The course is designed to gain the knowledge of basic concepts in proportioning and design of bridges in terms of aesthetics, geographical location.

### 10. **Course Outcomes:**

On completion of this course, the students will be able to

CO1. Identify different types and components of bridges and their evolution.

CO2. Distinguish different types of classifications of bridges as per IRC specifications, and calculate loads/forces acting on bridges.

CO3. Analyze and design bridges with IRC classifications.

CO4. Analyze various components of bridges with IRC classifications and draw SF and BM diagrams as per the loading conditions.

CO5: Design bridge foundations and bearings.

### 12. **Curriculum Content:**

#### Unit 1

**Introduction:** Definition, Components of bridge, Historical Developments, Site Selection for bridges, classification of bridges, Survey and data collection for a bridge site selection, Hydraulic design, Design Discharge, Linear waterway, Economical span.

#### Unit 2

**Specifications of Road Bridges** : Indian road Congress Bridge code, carriageway, clearance, forces on bridge, review of IRC loadings, applications of loads on bridge such as dead load, impact load, live load etc.

#### Unit 3

**R.C.C. Slab Culvert:** RCC Slab culvert, dead load BM and SF, BM and SF for IRC class AA tracked vehicle, BM and SF for IRC class AA wheeled vehicle, BM and SF for IRC Class A loading, structural design of slab culvert.

#### Unit-4

**T-Beam Bridge:** Proportioning of components, analysis of slab using IRC class AA tracked vehicle, structural design of slab, analysis of cross girder for dead load and IRC class AA tracked vehicle, structural design of cross girder, analysis of main girder using COURBON'S method, calculation of dead load and SF, calculation of live load BM and SF using IRC class AA tracked vehicle, structural design of main girder.

# **Course Structure & Syllabus of B.Tech.– Civil Engineering**

## **Applicable for Batch: 2020-24**

### **Unit- 5**

**Substructure, Foundations, Bearings, Joints and Appurtenances:** Definition of pier and abutment, design and drawing of pier and abutments, scour at abutments and pier, types of foundations, pile, well and pneumatic caissons, importance of bridge bearings, sketches of different types of bearings.

### **Text Books**

1. Raju, N. K., “Design of bridges”, Oxford and IBH publishing Co., New Delhi.
2. Victor, J., “Essentials of bridge engineering”, Oxford and IBH publishing Co., New Delhi, 3rd Edition, 1980.
3. *Indian Standard Codes: IRC:5, IRC:6, IRC:21, SP:16*

### **References**

1. Bindra, S. P., “Principles and practice of bridge Engineering”, DhanpatRai and Sons, New Delhi, 7<sup>th</sup> Edition, 1992.
- 2 “IRC 6-1966 Standard Specifications and code of practice for Road Bridges Section II loads and stresses”, The Indian Road Congress, New Delhi.
3. Bridge Deck Analysis, R. P. Pama & A. R. Cusens, John Wiley & Sons.
4. Design of Bridge Structures, T. R. Jagadish & M. A. Jairam, Prentice Hall of India, N. Delhi.

### **12. Teaching and Learning Strategy**

All materials (ppts, assignments, labs, etc.) will be uploaded in Moodle. Refer to your course in Moodle for details.☐

# Course Structure & Syllabus of B.Tech.– Civil Engineering

## Applicable for Batch: 2020-24

1.	<b>Department offering the course</b>	Civil Engineering
2.	<b>Course Code</b>	CEF443
3.	<b>Course Title</b>	Environmental Management & Sustainable Development
4.	<b>Credits</b>	3
5.	<b>Contact Hours (L:T)</b>	3 0 0
6.	<b>Prerequisites (if any)</b>	None
7.	<b>Course Basket</b>	Discipline Elective

8. **Course Summary:** Environmental Management & Sustainable Development describes about the interrelationship between various environmental elements and its management for sustainable growth.

9. **Course Objectives:** The objective of this course is to learn the knowledge of Environmental monitoring, environmental economics, making of and enforcing Environmental acts for the benefits of society and also about the realistic balance between environmental quality and resource utilizations.

### 10. Course Outcomes:

On completion of this course, the students will be able to

1. Identify the environmental components, interactions, scientific utilization of environmental resources
2. Have the complete knowledge about the Environment economics, legislations acts, Environment Protocols
3. Gain the idea about Environmental Impact Assessment
4. Gain the idea about Environmental sustainable development

### 11. Curriculum Content:

#### Unit 1

**Introduction:** Introduction and scope, Inter-linkages of energy-environment and economy from engineering infrastructure perspective.

#### Unit 2

**Environmental Resources, Monitoring and Management:** Concepts of environmental components and ecology, Systems approach and sustainability engineering, Interaction between energy and environmental resources, Environmental quality standards and indices (Indian and International), Environmental monitoring, Analysis, Statistics and data interpretation, Environmental management system.

#### Unit 3

**Environmental Laws and Policy:** Introduction to environmental laws and policies, Governance, understanding climate change, carbon crediting, carbon foot print etc., Introduction to trade and environment. International environmental laws, Right to Environment as Human Right, International Humanitarian Law and Environment, environment and conflicts management, Famous international protocols like Kyoto.

#### Unit 4

**Environmental Impact Assessment:** Environmental impact assessment, Life cycle assessment, Resource Balance, Energy Balance & Management, Review; Operational Control and risk analysis of scientific and technological developments, Environmental audit.

#### Unit 5

# **Course Structure & Syllabus of B.Tech.– Civil Engineering**

## **Applicable for Batch: 2020-24**

**Sustainable Development:** Sustainable development within the context of global economy, Technology and climate change, conservations of environmental resources.

### **Text Books**

1. Mishra, P. C., “Fundamentals of Air and Water Pollution”, APH Publishing Corporation, 2008.
2. Kenneth, W., Warner, F. C. and Davis W. T., “Air Pollution, Its Origin and Control”, Prentice Hall, 3<sup>rd</sup> Edition, 1997.
3. Baker, S., “Sustainable Development”, Routledge Publication, New York, 2008.

### **References**

1. Davis, M. L. and Cornwell, D. A., “Introduction to Environmental Engineering”, McGraw-Hill, 5<sup>th</sup> Edition, 2012.
2. Chin, D. A., “Water Quality Engineering in Natural Systems: Fate and Transport Processes in the Water Environment, John Wiley, 2<sup>nd</sup> Edition, 2012.

### **12. Teaching and Learning Strategy**

All materials (ppts, assignments, labs, etc.) will be uploaded in Moodle. Refer to your course in Moodle for details.



# Course Structure & Syllabus of B.Tech.– Civil Engineering

## Applicable for Batch: 2020-24

1.	<b>Department offering the course</b>	Civil Engineering
2.	<b>Course Code</b>	CEF444
3.	<b>Course Title</b>	Finite Element Analysis
4.	<b>Credits</b>	3
5.	<b>Contact Hours (L:T:P)</b>	2 1 0
6.	<b>Prerequisites (if any)</b>	Structural Analysis II
7.	<b>Course Basket</b>	Discipline Elective

8. **Course Summary:** Includes stress analysis based on discretization of structural elements into a finite number of individual elements

9. **Course Objectives:** This course aims to understand the basics of Finite Element Method and its application related to engineering problems.

### 10. Course Outcomes:

On completion of this course, the students will be able to

- 1: have understanding of finite element method.
- 2: know the applicability of FEM in various problems.
- 3: know the working of analysis software.
- 4: know the concepts of plate bending problems and techniques.

### 11. Curriculum Content:

#### Unit 1

**Introduction:** Basic concepts, Background review, Basic theory of finite Element method, application of finite element method, Advantages and disadvantages, matrix displacement formulation, simple application in structural analysis

#### Unit 2

**Fundamentals of Finite element Method:** Displacement function by stiffness matrix approach for bar element, 2D truss and beam element, application for FEM for the analysis of bar, truss, continuous beam.

#### Unit 3

**Analysis of 2D continuum Problems:** Element and shape function, Triangular, rectangular and quadrilateral element, different type of element, their characteristics and suitability for application, polynomial shape function, Lagrange's and Hermitian polynomial, compatibility and convergence requirements of shape functions.

#### Unit-4

**Theory of Isoparametric Element:** Isoparametric, Two dimensional isoparametric elements, computation of stiffness matrix, characteristics of isoparametric quadrilateral elements.

#### Unit- 5

**Introduction to plate bending problems and techniques:** Introduction to plate bending problems and techniques for nonlinear analysis, Structure of computer program for FEM analysis, description of different modules, pre and post processing.

### Text Books

1. Krishnamoorthy, C. S., "Finite Elements Analysis-Theory and Programming", Tata McGraw Hill Co. Limited, New Delhi.
2. Abel, J. F., Desai, C. S., "Introduction to the Finite element Method", Affiliated East West Press Pvt. Ltd., New Delhi.

# **Course Structure & Syllabus of B.Tech.– Civil Engineering**

## **Applicable for Batch: 2020-24**

### **References**

1. Bathe, K. J, “Finite Elements Procedure”, and PHI Pvt. Ltd, New Delhi.
2. Zienkeiwicz, O. C., “The Finite Element Method”, Tata McGraw Hill Co. Limited, New Delhi.

### **12. Teaching and Learning Strategy**

All materials (ppts, assignments, labs, etc.) will be uploaded in Moodle. Refer to your course in Moodle for details.

# Course Structure & Syllabus of B.Tech.– Civil Engineering

## Applicable for Batch: 2020-24

1.	<b>Department offering the course</b>	Civil Engineering
2.	<b>Course Code</b>	CEF445
3.	<b>Course Title</b>	Soil Dynamics and Machine Foundations
4.	<b>Credits</b>	3
5.	<b>Contact Hours (L:T:P)</b>	2 1 0
6.	<b>Prerequisites (if any)</b>	Soil Mechanics and Foundation Engineering
7.	<b>Course Basket</b>	Discipline Elective

**8. Course Summary:** The course deals with the behaviour and properties/response of soil as a material which is subjected to various types of dynamic or cyclic time-dependent loadings and hence will be very useful to undergraduate students to prepare the background for further study in the area of Geotechnical Earthquake Engineering and various related research and field applications for earthquake resistant design and construction of geotechnical systems.

**9. Course Objectives:** To understand the wave propagation in soils, determine dynamic properties of soil for analysing and designing foundations subjected to vibratory loading.

**10. Course Outcomes:**

On completion of this course, the students will be able to

1. Able to understand the fundamentals of wave propagation in soil media, evaluate the dynamic properties of soil, and design foundations for centrifugal and reciprocating machines

**11. Curriculum Content**

**Unit 1**

**Fundamentals of Vibration:** Definitions, Simple harmonic motion, Response of SDOF systems of Free and Forced vibrations with and without viscous damping, Frequency dependent excitation, Systems under transient loads, Rayleigh's method of fundamental frequency, Logarithmic decrement, Determination of viscous damping, Transmissibility, Systems with Two and Multiple degrees of freedom, Vibration measuring instruments.

**Unit 2**

**Wave Propagation and Dynamic Soil Properties:** Propagation of seismic waves in soil deposits – Attenuation of stress waves, Stress-strain behaviour of soils under cyclic loads, Strength of cyclically loaded soils, Dynamic soil properties – Laboratory and field testing techniques, Elastic constants of soils, Correlations for shear modulus and damping ratio in sand, gravels, clays and lightly cemented sand. Liquefaction of soils and its evaluation using simple methods.

**Unit 3**

**Vibration Analyses:** Types, General Requirements, Permissible amplitude, Allowable soil pressure, Modes of vibration of a rigid foundation block, Methods of analysis, Lumped Mass models, elastic half space method, elasto-dynamics, effect of footing shape on vibratory response, dynamic response of embedded block foundation, Vibration isolation.

**Unit 4**

**Design of Machine Foundations:** Analysis and design of block foundations for reciprocating engines, Dynamic analysis and design procedure for a hammer foundation, IS code of practice design procedure for foundations of reciprocating and impact type machines. Vibration isolation and absorption techniques.

**Unit-5**

**Machine Foundations on Piles:** Introduction, Analysis of piles under vertical vibrations, Analysis of piles under translation and rocking, Analysis of piles under torsion, Design procedure for a pile supported machine foundation.

# **Course Structure & Syllabus of B.Tech.– Civil Engineering**

## **Applicable for Batch: 2020-24**

### **Text Books:**

1. Swami Saran – Soil Dynamics and Machine Foundation, Galgotia Publications Pvt. Ltd. (2010)
2. Prakash, S. – Soil Dynamics, McGraw Hill Book Company (1981)

### **References:**

1. Prakash, S. and Puri, V. K. – Foundation for Machines: Analysis and Design, John Wiley & Sons, 1998.
2. Kameswara Rao, N. S. V. – Vibration Analysis and Foundation Dynamics, Wheeler Publication Ltd., 1998.
3. Das, B. M. & Ramana, G.V. – Principles of Soil Dynamics, 2nd Edition, CL Engineering Publishers, 2010.

### **12. Teaching and Learning Strategy**

All materials (ppts, assignments, labs, etc.) will be uploaded in Moodle. Refer to your course in Moodle for details.

# Course Structure & Syllabus of B.Tech.– Civil Engineering

## Applicable for Batch: 2020-24

1.	<b>Department offering the course</b>	Civil Engineering
2.	<b>Course Code</b>	CEF446
3.	<b>Course Title</b>	Advanced Reinforced Concrete Structures Design
4.	<b>Credits (L:T:P:C)</b>	4
5.	<b>Contact Hours (L:T:P)</b>	3 1 0
6.	<b>Prerequisites (if any)</b>	Design of Reinforced Concrete Structures
7.	<b>Course Basket</b>	Discipline Elective

8. **Course Summary:** Course provides knowledge on advanced RCC elemental design details

9. **Course Objectives:** The course is designed to familiarize students with design concepts of reinforced structures like curved beams, retaining walls, water tanks and multi storey frames.

### 10. Course Outcomes:

On completion of this course, the students will be able to

1. Understand yield line theory.
2. Design retaining walls
3. Design water tanks
4. Design curved Beams
5. Design multi-storey building frames

### 11. Curriculum Content

#### Unit 1

##### Yield Line Theory

Introduction to yield line theory. Design concept of beams and slabs by yield line theory.

#### Unit 2

**Design of Retaining Walls:** General specifications, Forces acting on retaining walls, Stability consideration, Wall proportioning, Design of cantilever type retaining walls, Design of counterfort type retaining walls.

#### Unit 3

**Design of Water Tanks:** Types of water tanks, Design of circular water tanks resting on ground with rigid base and flexible base. Concept of underground water tanks, Design of overhead water tank and Intz type tank.

#### Unit-4

**Design of Curved Beams:** Introduction to curved beams, Design of curved RC beams. Analysis of domes and circular plates.

#### Unit- 5

**Multi-storey Building Frames :** Introduction to multi-storey building frames, Analysis of multi-storey frames, Method of substitute frames and analysis and design of plane frames.

#### Text Books

1. Reinforced concrete design by N. Krishna Raju and R.N. Pranesh, New age International Publishers, New Delhi
2. Pillai, S. U., Menon, D., “Design of reinforced concrete structures”- Tata McGraw hill publications, 3rd Edition, 2009.
3. Varghese, P. C., “Advanced Limit State Design of Reinforced Concrete”, PHI Learning Pvt. Ltd., India

# **Course Structure & Syllabus of B.Tech.– Civil Engineering**

## **Applicable for Batch: 2020-24**

### **References**

1. Sinha, S. N., “Reinforced Concrete Design”, Tata McGraw Hill Publications, New Delhi, 2nd Edition, 2007.
2. IS 456: 2000, “Plain and Reinforced Concrete - Code of Practice”, 4th Revision, BIS, New Delhi.
3. SP 16: “Design Aid for RC to IS: 456-1978”, BIS, New Delhi.
4. SP 34: “Handbook on Concrete Reinforcement and Detailing”, BIS, New Delhi.
5. “Advance R.C.C. Design (R.C.C. Volume-II) ”S.S. Bhavikatti, New Age Publishers

### **12. Teaching and Learning Strategy**

All materials (ppts, assignments, labs, etc.) will be uploaded in Moodle. Refer to your course in Moodle for details.

# **Course Structure & Syllabus of B.Tech.– Civil Engineering**

## **Applicable for Batch: 2020-24**

1. Department offering the course	Humanities & Liberal Arts
2. Course Code	LAF281
3. Course Title	Introduction to Psychology
4. Credits (L:T:P:C)	3:0:0:3
5. Contact Hours (L:T:P)	3:0:0
6. Prerequisites (if any)	NIL
7. Course Basket	Humanities & Liberal Arts

### **8. Course Summary**

This course will highlight the most interesting scientific findings and insights of psychology, discussing the implications of those for our understanding of the human mind and human behaviour. We will explore some of the cognitive abilities including memory, learning, attention, perception and consciousness. We will examine the trajectory of growth of psychological perspectives. By the end of this course you will have gained a fascinating understanding and appreciation of who you are and how you work and relate with others. And I can guarantee you that you'll learn things that you'll be telling your friends and family about, things that will fundamentally change the way you think of yourself and others.

### **9. Course Objectives**

The purpose of this course provides coverage for the broad range of learning outcomes that may be taught in introductory psychology courses. With the goal of supporting faculty in the selection of content for their courses, we have organized this course around the 5 pillars, or domains, of psychology as recently recommended by the American Psychological Association: biological pillar, cognitive pillar, developmental pillar, and social and personality pillar, mental and physical health pillar.

### **10. Course Outcomes**

**On successful completion of the course, students will be able to achieve the following:**

1. Identify the various approaches, fields, and subfields of psychology along with their major concepts and important figures
2. Describe the strengths and weaknesses of descriptive, experimental, and correlational research
3. Explain how nature, nurture, and epigenetics influence personality and behaviour
4. Explain the physical, cognitive, and emotional development that occurs from infancy through childhood
5. Recognize aspects of social psychology, including the fundamental attribution error, biases, social roles, and social norms, in your daily life.

### **11. Curriculum Content**

#### **Unit 1 Introduction**

Definition, Scope, Perspectives: biological, psychoanalytic, behavioural, cognitive, humanistic, Methods: experiment, case study.

# **Course Structure & Syllabus of B.Tech.– Civil Engineering**

## **Applicable for Batch: 2020-24**

### **Unit 2 Cognitive Processes**

Perception: Meaning, laws of perceptual organization, identifying perceptual errors; Techniques for improving our behaviors: Classical conditioning, Reinforcement theory & Modeling; Creative Thinking & Problem-Solving

### **Unit 3 Motivation and Emotion**

Motivation: definition, self-motivation through goal setting, self-regulation, motivating employees, improving confidence; Emotion: definition, types, emotion and health, assessing emotional intelligence, body language.

### **Unit-4 Human abilities**

Self & Personality: definition, approaches for assessment, exploration through JOHARI Window; Understanding intelligence; Stress: meaning & coping; Conflict: definition & resolution;

### **TEXT BOOKS**

1. Baron, R.A. and Misra, G., Psychology (Indian Subcontinent Edition). Person Education Ltd. (2014)
2. Chadha, N.K. & Seth, S., The Psychological Realm: An Introduction. Pinnacle Learning, New Delhi. (2014)

### **REFERENCE BOOKS**

1. Ciccarelli, S.K. & Meyer, G.E., Psychology (South Asian Edition). New Delhi: Tata Mc Graw Hill. (2008).\
2. Glassman, W.F., Approaches to Psychology (3rd Ed.) Buckingham: Open University Press. (2000).
3. Passer, M.W., Smith, R.E., Holt, N. and Bremner, A., Psychology: The Science of Mind and Behaviour, McGraw-Hill Education, UK. (2008).

## **12. Teaching and Learning Strategy**

All materials (PPTs, Assignments, Seminars, etc.) will be uploaded in Moodle.



# **Course Structure & Syllabus of B.Tech.– Civil Engineering**

## **Applicable for Batch: 2020-24**

<b>1. Department offering the course</b>	<b>Humanities &amp; Liberal Arts</b>
<b>2. Course Code</b>	<b>LAF282</b>
<b>3. Course Title</b>	<b>Human Values</b>
<b>4. Credits (L:T:P:C)</b>	<b>3:0:0:3</b>
<b>5. Contact Hours (L:T:P)</b>	<b>3:0:0</b>
<b>6. Prerequisites (if any)</b>	<b>NIL</b>
<b>7. Course Basket</b>	<b>Humanities &amp; Liberal Arts</b>

### **8. Course Summary**

This course will introduce students to the nature of the individual and the relationship between the self and the community. It includes Principles of Interdependence between individuals and society and role of material values in promoting human well-being. It also includes psychological and spiritual values through topics like Humanistic Psychology, religion, concept of Dharma and Spirituality morality, Professional values and developing an open and balanced mind.

### **9. Course Objectives**

To inculcate the skills of ethical decision making and then to apply these skills to the real and current challenges of the Engineering profession. The main objective of the course is to enable the students to understand the need and importance of value-education and education for Human Rights. It also aims to develop their inter personal and leadership skills and empower them to develop into evolved human beings.

### **10. Course Outcomes**

**On successful completion of the course, students will be able to achieve the following:**

1. Students will become more sensitive to their surroundings including both people and nature, with commitment towards what they believe in (human values).
2. Be able to understand how universal values can be uncovered by different means, including scientific investigation, historical research, or public debate and deliberation (what some philosophers call a dialectic method).
3. They will become more aware of their self and their relationships and have better reflective and discerning ability.
4. Be able to understand and discuss the idea of moral relativism and the challenges it poses to universal values.

### **11. Curriculum Content**

#### **Unit 1 INTRODUCTION**

Nature of Value-Crisis in the contemporary Indian society, Meaning, Nature & Types of Values; Sources of Value Formation, Foundational Human Values – Integrity, Freedom, Creativity, Morals, Love and Wisdom, Case Studies Case Studies on the above aspects

# **Course Structure & Syllabus of B.Tech.– Civil Engineering**

## **Applicable for Batch: 2020-24**

### **Unit 2 SOCIETAL VALUES & MATERIAL VALUES**

Definition of Society, Units of Society, and Social Consciousness. Concepts & Principles of Interdependence, Conceptualizing 'Good Society' and 'Social Goods' and Corporate Social Responsibility, Role of Material Values in promoting Human Well-being. Role of Science and Technology; Problems of Material Development, Case Studies Case Studies on the above aspects

### **Unit 3 PSYCHOLOGICAL & SPIRITUAL VALUES**

Humanistic Psychology; Concept of Intelligence, Emotional Intelligence & Mental health; Cognitive Dissonance & Ego Defense, Maslow's Hierarchy of Human Need; Characteristics of 'Self-Actualizing' persons; Understanding Common Religion & Concept of Dharma and Spirituality; Case Studies Case Studies on the above aspects

### **Unit 4 PSYCHOLOGICAL & SPIRITUAL VALUES**

Bases for moral Judgments: Customary Morality, Religious Morality, Reflective Morality. Concept of Professional values: Competence , Confidence , Devotion to Duty, Efficiency , Accountability , Respect for learning / Learned , Willingness to Learn, Open and Balanced mind; Team spirit ; Willingness for Discussion, Aims, Effort , Avoidance of Procrastination and Slothfulness, Alertness, IIEEE; Case Studies Case Studies on the above aspects

#### **Textbook(s)**

1. Human Values - Prof. A.N.Tripathi New Age International, 2009

#### **Reference Books**

1. Human Values and Professional Ethics - Jayshree, Suresh and B.S. Raghwan , S. Chand Publication, 2011-12

#### **12. Teaching and Learning Strategy**

All materials (ppts, assignments, labs, etc.) will be uploaded in Moodle. Refer to your course in Moodle for details.

# **Course Structure & Syllabus of B.Tech.– Civil Engineering**

## **Applicable for Batch: 2020-24**

<b>1. Department offering the course</b>	<b>Humanities &amp; Liberal Arts</b>
<b>2. Course Code</b>	<b>LAF283</b>
<b>3. Course Title</b>	<b>Literature, Language &amp; Society</b>
<b>4. Credits (L:T:P:C)</b>	<b>3:0:0:3</b>
<b>5. Contact Hours (L:T:P)</b>	<b>3:0:0</b>
<b>6. Prerequisites (if any)</b>	<b>NIL</b>
<b>7. Course Basket</b>	<b>Humanities &amp; Liberal Arts</b>

### **8. Course Summary**

This course will introduce students about the literature, language & society. It also includes the overview of aspects of literature and language with its impact on the society. The course explores the dimensions of literature, its nature and its functions with its approaches to the study of society. It explores the role of language and literature in the society. The course will through study of text, also analyse the practical aspect of it.

### **9. Course Objectives**

The main objective of the course is to focus is on the interaction between literature & Society, and Literature and visual culture. This course is also about how Literature reacts to major changes in society. This course offers the students to experience different dimension of literature and language.

### **10 Course Outcomes**

**On successful completion of the course, students will be able to achieve the following:**

1. Students will read critically from a variety of genres, specifically poetry, drama, non-fiction, and fiction.
2. Students will read literature more carefully and meaningfully, practicing close-reading skills.
3. Students will understand the relation between historical and cultural contexts.
4. The students will develop a critical understanding of how literature can both uphold and resist existing structures of power.

### **11. Curriculum Content**

#### **Unit 1:**

Nature and Functions of Literature, Literature and Society with special reference to Indian Literature and Indian Society, Literary Forms, Poetry, Drama, Fiction, Essay, Autobiography

#### **Unit 2:**

Approaches to the Study of Literature, Reader response to the study of Literature, Interpretation, Appreciation, Evaluation, Special problems in understanding Modern Literature.

# **Course Structure & Syllabus of B.Tech.– Civil Engineering**

## **Applicable for Batch: 2020-24**

### **Unit 3:**

Social dimension of language. problems of multilingual communities, dominance and conflict, shift and attrition, language and the state, language and nation, Indian multilingualism, language variation, language and identity, linguistic prejudice and inequality, standardization, linguistic determinism, critical discourse analysis, and methodological issues.

### **Unit 4:**

Jerome K Jerome: Three Men on a Bummel (selection), Martin Amis: Last Days of Muhammad Atta, Li Ho: A Girl Comb her hair, R.K. Narayan: Malgudi Days (selection)

### **Textbook(s)**

1. Jerome K Jerome: Three Men on a Bummel (selection), Arrow smith Publications.
2. R.K. Narayan: Malgudi Days (selection), *Indian Thought Publications*.

### **Reference Books**

1. Martin Montgomery, An Introduction to Language and Society (Studies in Culture and Communication) Routledge; 2 edition (December 22, 1995).
2. Robe Pope, *An Introduction to Language Literature and Culture*.Routledge, 2005.

### **1. Teaching and Learning Strategy**

All materials (ppts, assignments, labs, etc.) will be uploaded in Moodle. Refer to your course in Moodle for details.

# **Course Structure & Syllabus of B.Tech.– Civil Engineering**

## **Applicable for Batch: 2020-24**

1. Department offering the course	Humanities & Liberal Arts
2. Course Code	LAF284
3. Course Title	Principles of Management
4. Credits (L:T:P:C)	3:0:0:3
5. Contact Hours (L:T:P)	3:0:0
6. Prerequisites (if any)	NIL
7. Course Basket	Humanities & Liberal Arts

### **8. Course Summary**

This course will introduce students about the basic Principles needed for management. It also includes case studies where a student can get idea about the actual working of the management field. Topics include Overview of Management, Management Information, and Planning Approach to Organizational Analysis, Motivation and Productivity.

### **9 Course Objectives**

The objective of this course is to familiarize B.Tech. Students with the roles, responsibilities, and skills required of modern managers. This course will be present the concepts of management as it applies to current thinking in the workplace.

### **10. Course Outcomes**

**On successful completion of the course, students will be able to achieve the following:**

- To present the topics in management, management theories, while at the same time focusing on practical applications in the real world especially for engineers.
- Evaluate the global context for taking managerial actions of planning, organizing and controlling.
- Assess global situation, including opportunities and threats that will impact management of an organization.
- Integrate management principles into management practices.

### **11. Curriculum Content**

#### **Unit 1 Overview of management**

Definition-Management-Role of managers-Organization and the internal and environmental factors – Trends and Challenges of Management in India.

Directing – delegation –span of control– communication, Controlling

#### **Unit 2 Management Information**

Introduction to functional areas of management, Operations management, Human resources management, Marketing management, Financial management

# **Course Structure & Syllabus of B.Tech.– Civil Engineering**

## **Applicable for Batch: 2020-24**

### **Unit 3 Planning Approach to Organizational Analysis**

Design of organization structure; job design and enrichment; job evaluation and merit rating

### **Unit 4 Motivation and Productivity**

Theories of motivation, Leadership styles and Managerial grid. Co-ordination, monitoring and control in organizations. Techniques of control; Few Cases on current management issues in India

#### **TEXT BOOKS:**

1. Schermerhorn, Management and Organisational Behaviour essentials, Wiley India
2. Koontz: Essentials of Management, PHI Learning.
3. Hirschey: Managerial Economics, Cengage Learning.
4. A V Rau: Management Science, BSP, Hyderabad
5. Mote, I Paul and Gupta: Managerial Economics Concepts & Cases, TMH, New Delhi.
6. Stephan R Robbins Fundamental of Management, Pearson

#### **REFERENCE BOOKS**

1. Koontz, H., and Wehrich, H., Essentials of Management: An International Perspective, 8th ed., McGraw Hill, 2009.
2. Hicks, Management: Concepts and Applications, Cengage Learning, 2007.
3. Mahadevan, B., Operations Management, Theory and Practice, Pearson Education Asia, 2009
4. Kotler, P., Keller, K.L, Koshy, A., and Jha, M., Marketing Management, 13th ed., 2009.
5. Khan, M.Y., and Jain, P.K., Financial Management, Tata-Mcgraw Hill, 2008.

### **12. Teaching and Learning Strategy**

All materials (ppts, assignments, labs, etc.) will be uploaded in Moodle. Refer to your course in Moodle for details.

# **Course Structure & Syllabus of B.Tech.– Civil Engineering**

## **Applicable for Batch: 2020-24**

<b>1. Department offering the course</b>	<b>Humanities &amp; Liberal Arts</b>
<b>2. Course Code</b>	<b>LAF381</b>
<b>3. Course Title</b>	<b>Positive Psychology and Living</b>
<b>4. Credits (L:T:P:C)</b>	<b>3:0:0:3</b>
<b>5. Contact Hours (L:T:P)</b>	<b>3:0:0</b>
<b>6. Prerequisites (if any)</b>	<b>NIL</b>
<b>7. Course Basket</b>	<b>Humanities &amp; Liberal Arts</b>

### **8. Course Summary**

This course provides an introduction to the science related to happiness, well-being, flourishing and the positive aspects of human experience. This course discusses research findings in the field of positive psychology. It also features practical applications of this science that you can put to use immediately to help you live a full and meaningful life.

### **9. Course Objectives**

The purpose of this course is to provide increase awareness for relevance of positive emotions at workplace. Students will gain psychological skills to maximize happiness and virtues like compassion, love and wisdom through experiential, workshop based and interactive activities along with assigned lectures and reading. Students will have an opportunity to explore the concepts (e.g., biological, psychological, social, emotional), the research behind the concepts, and evidence-based experiential activities that enhance well-being. Students will engage in a detailed analysis and evidence-based positivity change process utilizing validated questionnaires and positive psychology and well-being enhancing interventions.

### **10. Course Outcomes**

**On successful completion of the course, students will be able to achieve the following:**

1. Students learn about modern psychological knowledge of happiness.
2. Students acquire skills to cultivate positive emotions.
3. Measure and build individual, workplace and educational flourishing; plan, implement and assess positive psychology.
4. Students will gain an understanding of what contributes to well-being and how to build the enabling conditions of a life worth living.

### **11. Curriculum Content**

#### **Unit 1: What is positive psychology?**

Introducing Positive Psychology: Definition, goals, assumptions, key concepts and relationships with health psychology, developmental psychology, social psychology and psychology of religion, Meaning and measure of Happiness: Hedonic and Eudemonic perspective, Yogic notion of bliss

# **Course Structure & Syllabus of B.Tech.– Civil Engineering**

## **Applicable for Batch: 2020-24**

### **Unit 2: Positive Emotions, Cognitive states and Well-being**

What are positive emotions? The broaden and build theory, relevance of positive emotional states for physical, social & psychological resources, Positive emotions and well-being: Happiness and positive behavior, positive emotions and success, resilience, Self-efficacy, Optimism, Hope, Wisdom, Mindfulness and flourishing

### **Unit 3: How to enhance well-being?**

Use of postures, breathing practices, Sounds, dietary consumption

### **Unit 4: Positive Psychology at work place**

Maximizing achievement, conflict resolution, gratitude, positive leadership

### **Textbook(s)**

Snyder (2011). Positive Psychology: The Scientific and Practical Explorations of Human Strengths. New Delhi: Sage.

### **Reference Books**

1. Carr, A. (2004). Positive Psychology: The science of happiness and human strength.UK: Routledge.
2. Peterson, C. (2006). A Primer in Positive Psychology. New York: Oxford University Press.
3. Seligman, M.E.P. (2002). Authentic Happiness: Using the New Positive Psychology to Realize YourPotential for Lasting Fulfillment. New York: Free Press/Simon and Schuster.
4. Snyder, C.R., & Lopez,S.J.(2007). Positive psychology: The scientific and practical explorations of human strengths. Thousand Oaks, CA: Sage.
5. Snyder, C. R., & Lopez, S. (Eds.). (2002). Handbook of positive psychology. New York: Oxford University Press.

### **12. Teaching and Learning Strategy**

All materials (ppts, assignments, labs, etc.) will be uploaded in Moodle. Refer to your course in Moodle for details.



# Course Structure & Syllabus of B.Tech.– Civil Engineering

## Applicable for Batch: 2020-24

1. Department offering the course	Humanities & Liberal Arts
2. Course Code	LAF382
3. Course Title	Engineering Economics
4. Credits (L:T:P:C)	3:0:0:3
5. Contact Hours (L:T:P)	3:0:0
6. Prerequisites (if any)	NIL
7. Course Basket	Humanities & Liberal Arts

### 8. Course Summary

The course is devoted to teach basic concept of economics to the student of engineering. This includes basic concept of demand and supply of goods and services. Break-even point and evaluation is also included in this subject. Project evaluation and depreciation of physical assets are also key contribution in this subject. Finally, few concepts of banking system, inflation and business cycle are also the vital topics in this subject.

### 9. Course Objectives

- To provide the basic overview of economics in engineering perspectives.
- To increase the understanding of students to solve the engineering problems through economic theories.
- To increase the understanding of students to use economics theories in project investment of industries

### 10. Course Outcomes

**On successful completion of the course, students will be able to achieve the following:**

- Students will be able to apply economic principles and calculations to solve engineering projects.
- To students will be efficient to get the idea of production activities and its applications in industries
- Students will be competent to estimate the present and future value of money on their various investment plans.
- Develop the ability to account for time value of money using engineering economy factors and formulas, as well as the implications and importance of considering taxes, depreciation, and inflation.

### 11. Curriculum Content

#### Unit 1 General Overview of Economics

Nature and Scope of Economics in engineering perspective; **Theory of Demand Analysis:** Meaning and Types, Law of demand, Exceptions to the Law of Demand, Elasticity of Demand; **Theory of Supply Analysis:** Law of Supply and Elasticity of Supply; Mathematical Explanation on cost, revenue and profit function

#### Unit 2 Production Function and Its Applications

# **Course Structure & Syllabus of B.Tech.– Civil Engineering**

## **Applicable for Batch: 2020-24**

**Production Function:** Short-run and long-run Production Function; **Mathematical Explanation:** Laws of Returns to Scale & Law of Diminishing Returns Scale; **Concept of Cost and Its Types:** Total cost, fixed cost, variable cost, average variable cost, average fixed cost, marginal cost, explicit and implicit cost; **Break-Even-Analysis:** Importance and graphical presentation, mathematical problems

### **Unit 3 Time Value of Money and Project Evaluation**

**Time Value of Money:** Simple and Compound, Uniform Series Compound Interest Formula, Present Worth Analysis, Future Worth Analysis, Future Value through Annuity, Rate of Return Analysis, Cash flow diagrams; **Depreciation:** Introduction, Straight Line and Declining Balance Method of Depreciation; **Project Evaluation Techniques:** Present Worth Method, Future Worth Method, Annual Worth Method; **Benefit Cost Analysis:** Conventional and Modified B/C Ratio with PW method

### **Unit 4 Banking and Finance**

**Banking Sector:** Functions of the Commercial Bank and Central Bank, Financial Institutions; **Financial Market:** Money Market and Capital Market; **Monetary and Fiscal Policy:** Objectives, Instruments, Tools in Indian Economy; **Inflation:** Causes, Effects and Methods to Control it, Measurement of Inflation- Consumer Price Index and Whole Price Index; Deflation and Stagflation; **Business Cycles:** Various phases, Control and Measurement, Impact on business cycles on economic activities

### **TEXT BOOKS TEXT BOOKS**

1. Pravin Kumar (2015). Fundamental of Engineering Economics. Raj Kamal Press, New Delhi.
2. Riggs J.L., Dedworth, Bedworth D.B., and Randhawa, S.U. (1996). Engineering Economics. McGraw Hill International, New Delhi
3. PanneerSelvam R. (2001). Engineering Economics. Prentice Hall of India Ltd, New Delhi.

### **REFERENCE BOOK**

1. L.M. Bhole (2007). Financial Institutions and Markets. Tata McGraw Hill, New Delhi.

### **12. Teaching and Learning Strategy**

All materials (ppts, assignments, labs, etc.) will be uploaded in Moodle. Refer to your course in Moodle for details.

# **Course Structure & Syllabus of B.Tech.– Civil Engineering**

## **Applicable for Batch: 2020-24**

<b>1. Department offering the course</b>	<b>Humanities &amp; Liberal Arts</b>
<b>2. Course Code</b>	<b>LAF481</b>
<b>3. Course Title</b>	<b>Application of Psychology</b>
<b>4. Credits (L:T:P:C)</b>	<b>3:0:0:3</b>
<b>5. Contact Hours (L:T:P)</b>	<b>3:0:0</b>
<b>6. Prerequisites (if any)</b>	<b>NIL</b>
<b>7. Course Basket</b>	<b>Humanities &amp; Liberal Arts</b>

### **8. Course Summary**

This course will introduce students about knowledge in the various domains of psychology and its applications. It also includes theories of self, work motivation, job satisfaction, attitude and stress and its management.

### **9. Course Objectives**

The purpose of this course is to develop a broad base of knowledge in the various domains of psychology and its applications. This course is also about to synthesis and demonstrates of useful skills in the field of psychology namely areas of organization, society, stress management etc.

### **10. Course Outcomes**

**On successful completion of the course, students will be able to achieve the following:**

- a. The students will be able to understand basic concepts of psychology in major domains.
- b. The students will be able to apply the fundamentals of psychology in order to solve real life problems.
- c. The students will Use scientific reasoning to interpret psychological phenomena.
- d. To apply ethical standards to evaluate psychological science and practice

### **11. Curriculum Content**

#### **Unit 1: Role of Psychology in Understanding the Self**

Three Stages – Self-awareness, Self-acceptance and Self-realization; Exploration through JOHARI Window; Development of Self-Mead & Cooley

#### **Unit 2: Application of Psychology at Work Place**

Work Motivation: Theories and applications: Maslow, Herzberg, Goal Setting, Emotion: Emotional Quotient & Job Satisfaction, Early approaches to leadership, contemporary approaches to leadership- Transformational & Transactional Leadership, styles of leadership

#### **Unit 3: Application of Psychology in Personal & Professional Excellence**

Achieving Success: Creativity & Innovation; Role of attitude; Role of competence; Role of Self-

# **Course Structure & Syllabus of B.Tech.– Civil Engineering**

## **Applicable for Batch: 2020-24**

confidence; Time management; Role of Human Values.

### **Unit 4: Role of Psychology in Health & Fitness**

Stress & Coping Strategies: Meaning, Types, Sources, Effects of stress on health, and coping strategies; Characteristics of a healthy personality

#### **Textbook(s)**

1. R. Bayne, and I. Horton, Applied Psychology, Sage publications, 2003.
2. A. Furnham, The Psychology of Behaviour at Work, Psychology Press, 1997.
3. D. Harris, Engineering Psychology and Cognitive Ergonomics, Aldershot: Ashgate, 1997

#### **Reference Books**

1. Baron, R.A. and Misra, G., Psychology (Indian Subcontinent Edition). Person Education Ltd. (2014).
2. Ciccarelli, S.K. & Meyer, G.E., Psychology (South Asian Edition). New Delhi: Tata Mc Graw Hill. (2008).
3. Passer, M.W., Smith, R.E., Holt, N. and Bremner, A., Psychology: The Science of Mind and Behavior, McGraw-Hill Education, UK. (2008).
4. R. Gifford, (Ed.), Applied psychology: Variety and opportunity, Allyn and Bacon, 1991.
5. M.L. Blum, and J.C. Naylor, Industrial Psychology, CBS Publishers & Distributors, 1984.
6. D.M. Pestonjee, Stress and Coping: The Indian Experience, 2nd ed., Sage Publications, 1999.

### **13. Teaching and Learning Strategy**

All materials (ppts, assignments, labs, etc.) will be uploaded in Moodle. Refer to your course in Moodle for details.

# **Course Structure & Syllabus of B.Tech.– Civil Engineering**

## **Applicable for Batch: 2020-24**

<b>1. Department offering the course</b>	<b>Humanities &amp; Liberal Arts</b>
<b>2. Course Code</b>	<b>LAF482</b>
<b>3. Course Title</b>	<b>Intellectual Property Rights</b>
<b>4. Credits (L:T:P:C)</b>	<b>3:0:0:3</b>
<b>5. Contact Hours (L:T:P)</b>	<b>3:0:0</b>
<b>6. Prerequisites (if any)</b>	<b>NIL</b>
<b>7. Course Basket</b>	<b>Humanities &amp; Liberal Arts</b>

### **8. Course Summary**

The course offers a comprehensive intellectual property subject that is easy to understand for students. The intellectual property rights syllabus comprises topics ranging from patent registration to copyrights and trademarks, and examples are based on familiar situations that the students encounter in their day-to-day lives. Topics would include the major aspects of IPR, which include analysing an idea, patent search techniques, which also helps them to boost their career with additional industry-relevant skills.

### **9. Course Objectives**

The purpose of this course is to provide the basic understanding of intellectual property rights, the rationale behind making provision for these rights and the recent concerns in the field. The main objective of the course is to increase the attention of students to protect their IP through legal provision and also teach the students how they can reduce the imitation rate. This course also helps to teach the students the understanding their involvement in technology transfer and commercialization.

### **10. Course Outcomes**

**On successful completion of the course, students will be able to achieve the following:**

1. The students will be able to understand the importance of IPRs in academic field.
2. The student gets idea how they can protect their IP through IPRs regime.
3. The student gets more incentive towards technology transfer and commercialization
4. Apply intellectual property law principles (including copyright, patents, designs and trademarks) to real problems and analyse the social impact of intellectual property law and policy

### **11. Curriculum Content**

#### **Unit 1: Introduction to IP**

Public Funded Research and Its Implications in an Economy; Public Funded Research and Economic Development; Research & Development and Industrial Development

#### **Unit 2: Historical Perspectives of IPRs**

History and concept of Property; Introduction to intellectual property rights (IPRs); Patent, Industrial design; Copyrights, Trademarks, Geographical Indications; Trade Secrets; International aspect of IPRs; Development at International level regarding IPRs

# **Course Structure & Syllabus of B.Tech.– Civil Engineering**

## **Applicable for Batch: 2020-24**

### **Unit 3: Polices on IPRs in India**

The debate: Copyright vs Copy left; Research ethics; role of IPRs in economic development in developed and developing economies; Overview of Various Policies on IPRs in India; Success Story of Bayh Dole Act of IPRs in USA

### **Unit 4: IPRs and Technology Commercialization**

Technology Transfer and Commercialization; Key Determinants and Participants of Technology Transfer and Commercialization; Types of Technology Transfer and Commercialization; Technology Transfer and Commercialization in India and Other Developing Economies

### **Textbook(s)**

1. Cornish, W.R. and L. David. 2010. 7<sup>th</sup> Edition. Intellectual Property: Patents, Copyrights, Trademarks and Allied Rights. Sweet and Maxwell.
2. Narayan, P. 2002. Intellectual Property, Law in India, 3<sup>rd</sup> Ed. New Delhi, Delhi Law House.
3. Ganguli, P. 2001. Intellectual Property Rights: Unleashing the Knowledge Economy. Tata McGraw Hills.
4. Watal, J. 2001. Intellectual Property Rights in the WTO and Developing Countries. New Delhi: Oxford University Press.

### **Reference Books**

1. Singh A.K., Ashraf S.N. and Acharya S.R. 2017. Viability of Bayh Dole Act of USA in the context of India: Critical evidence from review of literature, in Sasi Misra.
2. Sunil Shukla and GanapathiBatthini (Eds). Proceedings of the 12<sup>th</sup> Biennial Conference on Entrepreneurship Organized by EDII Ahmedabad (pp. 235-252). Bookwell Publishing House: New Delhi

### **12. Teaching and Learning Strategy**

All materials (ppts, assignments, labs, etc.) will be uploaded in Moodle. Refer to your course in Moodle for details.

# **Course Structure & Syllabus of B.Tech.– Civil Engineering**

## **Applicable for Batch: 2020-24**

1.	Department offering the course	Humanities & Liberal Arts
2.	Course Code	LAF285
3.	Course Title	Indian Constitution
4.	Credits (L:T:P:C)	2:0:0:2
5.	Contact Hours (L:T:P)	2:0:0
6.	Prerequisites (if any)	NIL
7.	Course Basket	AEC

### **8. Course Summary:**

The Constitution of India is the supreme law of India. The document lays down the framework demarcating fundamental political code, structure, procedures, powers, and duties of government institutions and sets out fundamental rights, directive principles, and the duties of citizens. The course will provide knowledge of their constitutional rights to the students and also familiarize the students with the features of the Indian Constitution.

### **9. COURSE OBJECTIVE:**

- To familiarize the students with the features of the Indian Constitution
- To provide a knowledge of their constitutional rights

### **10. Course Outcomes**

**On successful completion of the course, students will be able to achieve the following:**

- Enable the students to protect their rights
- The students will be engaged in the political system of India

### **11. Curriculum Content**

#### **Unit 1: Introduction**

Constitution- meaning of the term, basic features Indian Constitution: Sources and constitutional history, Features: Citizenship, Preamble, Fundamental Rights and Duties, Directive, Principles of State Policy, debates on Fundamental Rights and Directive

#### **Unit 2: Union Government and its Administration**

Structure of the Indian Union: Federalism, Centre- State relationship, President: Role, power and position, PM and Council of ministers, Cabinet and Central Secretariat, Lok Sabha, Rajya Sabha Institutional Functioning: Prime Minister, Parliament and Judiciary, Power Structure in India: Caste, class and patriarchy

#### **Unit 3: State Government and its Administration**

Governor: Role and Position, CM and Council of ministers, State Secretariat: Organisation, Structure and Functions.

#### **Unit-4 Local Administration**

District's Administration head: Role and Importance, Municipalities: Introduction, Mayor and role of Elected, Representative, CEO of Municipal Corporation, Pachayati raj: Introduction, PRI: Zila Pachayat, Elected officials and their roles, CEO Zila Pachayat: Position and role, Block level:

# **Course Structure & Syllabus of B.Tech.– Civil Engineering**

## **Applicable for Batch: 2020-24**

Organizational Hierarchy (Different departments), Village level: Role of Elected and Appointed officials, Importance of grass root democracy

### **Unit 5: Election Commission**

Election Commission: Role and Functioning, Chief Election Commissioner and Election Commissioners, State Election Commission: Role and Functioning, Institute and Bodies for the welfare of SC/ST/OBC and women

### **TEXT BOOKS**

1. Abbas, H., Kumar, R. & Alam, M. A. (2011) Indian Government and Politics. New Delhi: Pearson, 2011.
2. Chandhoke, N. & Priyadarshi, P. (eds.) (2009) Contemporary India: Economy, Society, Politics. New Delhi: Pearson.

### **REFERENCE BOOKS**

1. Chakravarty, B. & Pandey, K. P. (2006) Indian Government and Politics. New Delhi: Sage.
2. Chandra, B., Mukherjee, A. & Mukherjee, M. (2010) India After Independence. New Delhi: Penguin.
3. Singh, M.P. & Saxena, R. (2008) Indian Politics: Contemporary Issues and Concerns. New Delhi: PHI Learning.
4. Vanaik, A. & Bhargava, R. (eds.) (2010) Understanding Contemporary India: Critical Perspectives. New Delhi: Orient Blackswan.

### **12 Teaching and Learning Strategy**

All materials (ppts, assignments, labs, etc.) will be uploaded in Moodle. Refer to your course in Moodle for details.



## **Course Structure & Syllabus of B.Tech.– Civil Engineering**

### **Applicable for Batch: 2020-24**

<b>13. Department offering the course</b>	Civil Engineering
<b>14. Course Code</b>	CEF482
<b>15. Course Title</b>	Natural Dynamics
<b>16. Credits</b>	3
<b>17. Contact Hours (L:T:P)</b>	3 0 0
<b>18. Prerequisites (if any)</b>	None
<b>19. Course Basket</b>	Free Electives

**20. Course Summary:** Subject covers the fundamental study about the Natural Dynamics.

**21. Course Objectives:** The course provides wide knowledge about environmental process and sustainability.

**22. Course Outcomes:**

After completion of this course, the student will be able to

CO1: Remember the basic knowledge of environmental process and causes of pollution

CO2: Explain the concepts of air, water quality parameters, purification process and apply in real scenario

CO3: Explain the concepts of noise pollution assessment and solid waste management

CO4: Analyze the ecological and problems and create a sustainable environment

*CO5: Appreciate the elements and scope of Sustainable Development Goals.*

**23. Curriculum Content:**

**Unit -1: Environment**

**5L**

Environment and its components, pollution of environment by human activity, kinds of pollution.

**Unit-2: Water and Air Quality**

**14L**

**Water Quality**

Measure of water quality, water quality standards, water treatment; waste water transport and treatment, sludge treatment and disposal. Water quality indices, quantification of water parameters.

**Air Quality**

Sources and effects of air pollution, major air pollutants, air quality control, treatment of emissions, dispersion of air pollutants. Air quality indices.

**Unit-3: Noise Pollution Assessment and Solid Waste Management**

**8L**

**Solid waste**

Collection of refuse, removal and transport, disposal of refuse. Energy generation from waste.

**Noise Pollution**

Effect of noise on human health and its control. Use of sound energy.

**Unit-4: Ecology**

**6L**

Ecology and Ecosystems, concept of ecological imbalances, physical and climate factors, biotic components, energy and material flows in ecosystems, human influence on ecosystems.

# **Course Structure & Syllabus of B.Tech.– Civil Engineering**

## **Applicable for Batch: 2020-24**

Herbivore-Ecosystem Interactions.Population Regulation in an Ecosystem.Law of thermodynamics in ecology.

### **Unit-5: Conservation of Natural Resources**

**6L**

Water resources, mineral resources, agricultural and forestry resources, agriculture soil and need of nutrients, fertilizers and pesticides. Brief introduction about environmental legislation and environmental audit.

### **12. Books Recommended:**

1. Vesilind, "Introduction to Environmental Engineering," Thomson Asia Pvt. Ltd. Singapore.

### **13. Teaching and Learning Strategy**

All materials (ppts, assignments, labs, etc.) will be uploaded in Moodle. Refer to your course in Moodle for details.

# Course Structure & Syllabus of B.Tech.– Civil Engineering

## Applicable for Batch: 2020-24

<b>Subject Code</b>	CEF483	<b>Subject Title</b>	GIS						
<b>LTP</b>	3 0 0	<b>Credit</b>	3	<b>Subject Category</b>	OE	<b>Year</b>	4th	<b>Semester</b>	VIII

**Course Objective:** The course provides wide knowledge about basics of GIS and its applications in various fields

**Unit-1: Introduction to DEM** **8L**

Definition of GIS, Cartography and GIS, GIS database: spatial and attribute data; Spatial models: Semantics, spatial information, temporal information, conceptual models of spatial information, representation of geographic information: point, line and area features, topology,

**Unit-2: Derivation of Terrain Factors from DEM** **12L**

Raster and vector data, raster to vector data conversion, map projection, analytical transformation, rubber sheet transformation, manual digitizing and semi-automatic line following digitizer; Remote sensing data as an input to GIS data;

**Unit-3: Classifications and Functions** **10L**

Attribute database: scale and source of inaccuracy; GIS functionality; data storage and data retrieval through query, generalization, classification, containment search within a spatial region;

**Unit-4: Index and Matrix Overlay** **5L**

Overlay: arithmetical, logical and conditional overlay, buffers, inter visibility, aggregation; Network analysis;

**Unit-5: Applications** **4L**

Applications of GIS in planning and management of utility lines and in the field of environmental engineering, geotechnical engineering, transportation engineering and water resources engineering.

**Course Outcome (Old):**

On completion of this course, students will be able to:

CO1. Basic understanding of GIS concepts, components.

CO2. Analyzing geo-spatial data with various techniques and GIS tools

CO3. Apply the concepts in solving environmental and engineering problems

CO4. Create new information and theoretical knowledge after applying GIS tools

**Course Outcomes (New):**

On completion of this course, students will be able to:

CO1. Understand the basic concepts of GIS and apply this knowledge to understand the real time satellite data.

# **Course Structure & Syllabus of B.Tech.– Civil Engineering**

## **Applicable for Batch: 2020-24**

CO2. Identify the basic components of geospatial data and able to use the GIS tool for solving the real time problem.

CO3. Understand the concept of database management system and able to use this concept in real time projects.

CO4. Able to create various models and maps by using the concepts of overlay, buffers and network analysis.

CO5. Apply the knowledge of GIS in various discipline and able to formulate new ideas.

### **Books Recommended:**

1. Geographic Information Systems: A Management Perspective, by Stan Arnoff, WDL Publications.

2. Fundamentals of Spatial Information Systems by Robert Laurini and Derek Thompson, Academic Press.

3. Geographical Information Systems, Vol. I and II edited by Paul Longely, M.F. Goodchild, et.al, John Wiley and Sons, Inc. 1999